

READING BLUE MOUNTAIN AND NORTHERN RAILROAD INDUSTRIAL DEVELOPMENT SIDETRACK SPECIFICATIONS



"The Road of Anthracite"

EST. January 25, 2007
Rev. January 7, 2020

TABLE OF CONTENTS

Introduction
Definitions
Section 1 – New Track Design
Section 2 - Clearing, Grubbing, Grading and Seeding
Section 3 - Drainage
Section 4 - Materials
Section 5 - General Construction
Section 6 - Crossings
Section 7 - Bridges, Trestles, Box Culverts and Unloading Pits
Section 8 - Scales
Section 9 - Hazardous Commodities
Section 10 - End of Maintenance Signage

Plan No. 1-0	Spikes
Plan No. 2-0	Roadbed Section for Heavy Tonnage Tracks
Plan No. 3-0	Roadbed Section for Industrial Tracks
Plan No. 4-0	No. 8 132/136 RE Turnout
Plan No. 5-0	No. 10 132/136 RE Turnout RBM Frog
Plan No. 6-0	Data on Turnouts and Crossovers
Plan No. 7-0	Switch Point Derail
Plan No. 8-0	Bow Handled Throwing Lever
Plan No. 9-0	Turnout Design Schematic
Plan No. 10-0	Close Clearance Sign
Plan No. 11-0	Clearances for Tracks Located on Industry Property
Plan No. 12-0	Track Spiking Pattern
Plan No. 15-0	Earth Mound Detail
Plan No. 16-0	Installation Instructions for Corrugated Metal Drainage Structures
Plan No. 17-0	Corrugated Metal Culvert Gage Selection and Installation
Plan No. 18-0	Criteria for Temporary Sheeting and Bulkheads to Protect Railway Track During Adjacent Structure Construction
Plan No. 19-0	Oil Siding Protection From Stray Electric Currents
Sign Diagram No. 20-0	Switches Lined and Locked
Sign Diagram No. 21-0	Standard Switch Target
Sign Diagram No. 22-0	Derail Sign

INTRODUCTION

Information contained in these specifications applies to privately owned industry tracks only. The intent of these specifications is to provide industries, desiring rail service from the Reading Blue Mountain & Northern Railroad, with information to aid in the design, construction and/or rehabilitation of the proposed railroad tracks. It is our expressed hope that these specifications can be of benefit in the development or expansion of your rail served facilities.

In general, the industry shall rehabilitate, construct, or cause to be constructed, the subgrade (embankment or excavation), subballast, and all drainage necessary for the installation of the track and track structure. This typically includes all work required for that portion of the track on the railroad's right-of-way.

The entire Reading Blue Mountain & Northern team is committed to working with you in developing a rail service plan which enables you, our valued customer, to maximize both current and long-term business opportunities. **Prior to commencement of train service on the track, both the Industry and the Railway Company shall execute an operating contract in accordance with standard procedure of the railway company.**

The following pages cover requirements and/or recommendations for privately owned Industry tracks to be served by Reading Blue Mountain & Northern Railroad.

We look forward to serving you!

DEFINITIONS

When the following definitions are used in these Specifications, it is understood that they have the meaning herewith given:

COMPANY

That operating rail subsidiary of Reading Blue Mountain & Northern Railroad within whose territory the project is being constructed.

INDUSTRY

That company and/or individual for which a rail siding, and/or lead track is to serve.

CHIEF ENGINEER, ENGINEER OPERATING OFFICER

The officer of the Railway Company acting for and in behalf of the Railway Company in its transactions or the authorized representative of such an officer.

PLANS

The plans, drawings, maps, cross sections, and/or profiles showing the character of the work prepared as a guide for construction of the proposed track.

TURNOUT/SWITCH

An arrangement of switch points and a frog with closure rails, and appurtenances by means of which rolling stock may be diverted from one track to another.

CLEAR POINT

That point where there is a 15-foot spread between main track centers and an adjacent track and 14-foot for other tracks as measured between centers, allowing the passing of freight cars and/or locomotives safely.

LEAD TRACK

Track serving or having the ability to serve more than one industry which has individual spur tracks for each industry.

SPUR TRACK

Track serving only one industry.

RUNAROUND TRACK

Track used by an engine to run around to the other end of a string of cars.

SWITCHING TRACK

Track used to set off cars, runaround cars and/or to facilitate the general switching operations to serve an industry.

SECTION 1 – NEW TRACK DESIGN

GENERAL

The following sections govern the criteria to be used in the designing of industry tracks. Any deviation from these requirements must be approved by the Railway's Chief Engineer or designated representative.

HORIZONTAL CURVATURE

Tracks should be designed utilizing the minimum degree of curvature practicable, but must be limited to a **maximum of 12 degrees (radius = 478.34 feet) on spur tracks and 10 degrees (radius = 573.69 feet) on lead tracks**. Calculations for horizontal curves must be based on the chord definition.

Where reverse curves are to be used, it will be necessary to provide preferably 100 feet, but a minimum of 70 feet, of tangent between the point of tangency of the preceding curve and the point of curvature of the next curve.

Spiral curves and/or super elevation shall only be required where the speed of operation so dictates. Designs for lead tracks one mile or longer will be evaluated by the Company on an individual basis to determine if spirals and super elevation are required.

Horizontal curves must not begin on the long ties of a turnout.

VERTICAL CURVES

Vertical curves must be provided at break points in the profile of the track and should be as long as practicable.

Vertical curves must not begin on the long ties of a turnout. The grade from the switch point through the long ties of the proposed turnout must be the same as the existing track from which it springs. Minimum length of vertical curves in feet shall be as follows:

- a. for lead tracks:
100 times the algebraic difference of grades in percent for summits and sags, i.e. maximum rate of change for summits and sags = 1.0
- b. for spur tracks up to 1500 feet in length:
33.3 times the algebraic difference of grades in percent for summits and 40 times the algebraic difference for sags, i.e. maximum rate of change for summits = 3.0 and maximum rate of change for sags = 2.5
- c. for spur tracks over 1500 feet in length:
40 times the algebraic difference of grades in percent for summits and 50 times the difference for sags, i.e. maximum rate of change for summits = 2.5 and maximum rate of change for sags = 2.0

GRADES

Track grades should be kept to a minimum and shall be restricted to a maximum of 2% (compensated) on lead tracks, and 3 % (compensated) on individual spur tracks. Grade compensation for curvature will be 0.04 percent per degree of curvature. The section of a track where rail cars are placed for loading or unloading should have a 0.0% grade.

CLEARANCES

Standard vertical and horizontal clearances are shown on Plan No: RBMN 11-0, attached to these guidelines. All substandard clearances must have the approval of the responsible operating officer of the Company provided that the Company Clearance Engineer determines that there are no equipment restrictions for the proposed plans.

COUPLING CLEARANCE

A minimum of 70 feet of tangent track from the first car's coupling point and Point of Tangent is required. In the case of land constraints, this minimum distance may be reduced with approval from the Company's Operations Department.

TURNOUTS/SWITCHES

All main track turnouts will be No. 10 or larger. Turnouts in sidetracks will also be No. 10 unless space will not permit, in which case a No. 8 turnout will be considered. Reference Standard Plan No: RBMN 6-0 and the Turnout Design Schematic, Plan No: RBMN 9-0, for turnout geometry. Standard No. 8 and No. 10 turnouts are shown on Plan No: RBMN 4-0 and No: RBMN 5-0.

For two turnouts in the same track diverging in opposite directions, thereby creating a reverse curve situation, it will be necessary to provide preferably 100 feet but a minimum of 70 feet between the points of switches of the two turnouts.

For a main track turnout diverging in the same direction as a preceding curve, as much tangent as possible should be allowed, but the turnout cannot be placed before the end of the spiral.

For a main track turnout diverging in the opposite direction from the preceding curve, the turnout cannot be placed before 100 feet beyond the end of the spiral.

All work on the main tracks, including main track turnouts, shall be accomplished by the Railway Company.

ROADBED SECTION

Requirements for roadbed shoulder width, ditches, and slopes are shown on Plan No: RBMN 2-0 (heavy tonnage tracks other than main tracks), and RBMN 3-0 (industrial tracks) attached to these guidelines. Industry should note the importance of constructing these typical roadbed sections, which will provide an adequate walkway for both Company and Industry personnel. This is especially true in the area between switch stands and derails, and any other areas as dictated by Local, State, or Federal regulations.

SECTION 2 - CLEARING, GRUBBING, GRADING, AND SEEDING

CLEARING AND GRUBBING

The term "clearing and grubbing" includes the removal of all trees, brush, logs and other perishable or undesirable materials from places where new construction is to occur.

The Industry shall be responsible for the clearing and grubbing of that portion of the Company's right-of-way, only with permission of Chief Engineer and Inspector, affected by the new construction. All material removed from the Company's right-of-way, excepting that reserved by the Company, shall be disposed of by the Industry. The Industry shall be responsible for the identification and protection of overhead and underground utility easements, including fiber optic cable easements, within the Company's right-of-way.

GRADING

The Industry shall construct or cause to be constructed all grading necessary for the installation of the track. This includes the grading required for that portion of the track on the Company's right-of-way. The Industry shall be responsible for the identification and protection of overhead and underground utility easements, including fiber optic cable easements, within the Company's right-of-way. Prior to commencement of grading work, the Industry must contact the Company's Division Engineer's and Division Superintendent's office to coordinate the grading so as not to interfere with normal train operations. The Industry shall be responsible for adhering to all Local, State, and/or Federal permits such as erosion control, grading, storm water runoff/drainage, etc.

Fills and subgrades shall be compacted to minimum of 90% Modified Procter based on American Association of State Highway and Transportation Officials (AASHTO) Designation T-180, or 95% Standard Procter based on AASHTO Designation T-99.

Moisture content of soil should be controlled as necessary to obtain specified densities, based on the moisture-density relationship developed by AASHTO tests.

Slopes of all cuts shall be true and straight and all loose stones and boulders removed. Slopes of all fills shall be carefully formed and trimmed as they become compacted. Where a fill is placed on sloping ground or on the side of an existing fill, the surface shall be deeply plowed or stepped and the new material thoroughly mixed and embodied with the old material as the new fill is made and compacted.

The finished subgrade shall conform to such elevations as shown or otherwise noted on the plans, within a tolerance of ± 0.1 foot.

SUBBALLAST

Subballast shall be crusher-run stone (dense graded aggregate), preferably limestone or granite material and shall meet the requirements as set out in Chapter 1, Part 2, Article 2.11 "Specifications for Subballast" of the American Railway Engineering and Maintenance-of-Way Association (AREMA) manual.

Acceptable subballast is AASTO #57, also referred to as "2B driveway stone."

Gradation as follows:

Sieve Size	2"	1"	3/8"	No. 10	No. 40	No. 200
% Passing Size (optimum)	100	95	67	38	21	7
Permissible Range % Passing	100	90-100	50-84	26-50	12-30	0-10

Subballast shall be spread on a graded roadbed of no less than 16' wide, as a base, with sufficient width to accommodate the desired number of tracks (see Plans Nos. RBMN 2-0 and RBMN 3-0, attached to these guidelines). The subballast shall have a minimum depth of 2-6 inches. (For 6 inches of compacted sub-ballast on a single industry track roadbed as per Plan No. RBMN 3-0, use approximately 0.83 ton per foot of track)

SEEDING

A native Pennsylvania seed and fertilizer mixture shall be applied so as to provide adequate slope protection. Creeping grasses shall not be used.

SECTION 3 - DRAINAGE

GENERAL

The Industry shall construct, or cause to be constructed, at its own expense, all drainage structures for the proposed track including that portion of the track on the Company's right-of-way. Any change or additions to existing drainage structures under the Company's tracks, required because of the proposed track, shall be the responsibility of the Industry. The Industry shall be liable for all claims from upstream and downstream property owners for any damages due to changes in existing drainage. The Industry shall furnish to the Company for review, plans and specifications for proposed drainage structures and drainage changes involving the Company's right-of-way prior to start of construction.

All pipe shall conform to American Railway Engineering and Maintenance-of-Way Association (AREMA) or American Society for Testing and Materials (ASTM) specifications for culvert pipe under railroads and be designed to carry Coopers E-80 loadings. All pipe shall be installed to the line, grade, and elevations and be of the size as shown on plans approved by the Company.

All pipe shall be installed for the full width of section, properly bedded as per attached Installation Of Corrugated Metal Drainage Structures, Plan No. RBMN 16-0, and shall be back filled with select material and carefully compacted.

CORRUGATED METAL PIPE

The following requirements will be met for all corrugated metal pipe placed under Company tracks or tracks that will be owned by the Company at some time later.

Corrugated metal pipes shall be of adequate cross section to provide proper drainage opening and have a minimum of 36 inches inside diameter and a wall thickness to carry Coopers E-80 loadings with adequate cover but at no time shall be less than 12 gage. See the Gage Selection of Corrugated Metal Pipes Detail, attached.

All corrugated metal pipes to be installed under tracks on Reading Blue Mountain & Northern Railroad right-of-way or easements to be conveyed to Reading Blue Mountain & Northern Railroad in the future, shall be galvanized, annular, riveted, and fully asphalt coated for normal soil and water conditions. Helically corrugated pipe with annular re-rolled ends may not be used within Railway Company's right-of-way or easements to be conveyed to the Railway Company. The re-rolled ends should be manufactured to accommodate 2 feet wide connecting bands. Corrugated metal pipe used under "acidic" conditions (pH, factor ≤ 4.0) such as in mine water should be either fiber bonded, epoxy bonded or polymer coated. Where the streambed consists of sand and gravel, or other abrasive conditions exist, the invert shall be paved.

Corrugated metal pipes of 48 inches or larger diameter will be formed to a specified 5 percent vertical elongation with tension wires or turnbuckle rods at horizontal axis. These tension wires are to be removed when grading is complete.

CONNECTING BANDS

Connecting bands for annual bituminously coated corrugated metal pipe shall consist of a single piece 24 inches wide, one gage lighter, with the same corrugations and same cover treatment as the drainage pipe. Connecting bands for drainage pipe 48

inches and larger diameter will be fully bolted with a minimum of four – 0.5 inch circumferential rods and silo-type lugs. See the Corrugated Metal Culvert Gage Selection and Installation Plan No: RBMN 17-0.

Dimpled bands are not acceptable.

CONCRETE PIPES

Concrete pipes shall not be allowed under Company owned tracks or tracks that will be owned by the Company at a later date. The following requirements shall be met for all concrete pipe placed under Industry tracks over which Reading Blue Mountain & Northern Railroad equipment will operate:

Concrete pipes shall be of adequate cross section to provide proper drainage, reinforced Wall B, and shall conform to ASTM C-76 Class V concrete pipe. A minimum inside pipe diameter of 36 inches is suggested.

The use of pre-cast concrete box culverts is acceptable. Boxes must be designed and fabricated in accordance with the current AREMA Manual for Railway Engineering. Chapter 8, for Coopers E-80 Live Loading.

PAVED INVERTS – END TREATMENT

Paved inverts and/or end treatment will be provided where soil and water conditions or facility design requires, and when designated by the Company.

DITCHES

The Industry shall provide temporary or permanent ditches in order to maintain the Company's existing drainage of the tracks. No ponding of water against the Company's existing roadbed shall be allowed. Ditches draining Company tracks shall be designed to carry the expected flows of a storm with a 100-year recurrence interval.

No drainage is to be diverted to railroad ditches without the specific notification and approval of the Company. Also, additional runoff created due to paving or structures within existing drainage basins, which drain toward Company property, must be released through a control structure such as a detention pond.

SECTION 4 - MATERIALS

BALLAST

Material for ballast shall be clean crushed stone with a minimum depth of 9 inches for main leads and 6 inches for industry tracks between bottom of crosstie and top of sub-ballast (see Plan Nos. RBMN 2-0 and RBMN 3-0 attached to these guidelines) Cribbs (spacing between the crossties) shall be filled with ballast to the top of the ties.

Stone for use as ballast on tracks, or portions of tracks, to be owned by the Company, shall be furnished by a Company approved quarry, and shall be crushed stone (granite) conforming to the requirements of Reading Blue Mountain & Northern Railroad. **In some regions, if approved by the Railway's Chief Engineer, limestone may be used.**

Gradation shall conform to the following table:

Sieve Designation	Sieve Opening	#3 Ballast (Modified % Passing Sieve	#5 Ballast % Passing Sieve
2 1/2"	2.5"	100	-
2"	2"	95-100	-
1 1/2"	1.5"	30-65	100
1"	1"	0-15	90-100
3/4"	0.75"	-	40-75
1/2"	0.5"	0-5	15-35
3/8"	0.375"	-	0-15
No.4	0.187"	-	0-5
No. 200	0.0029"	0.5 Max	0.5 Max

3 Ballast (Modified) will be used under all main tracks or switching leads. (See Plan No. RBMN 2-0 attached.)

#5 Ballast should be used under all yard tracks and ladder tracks.

RAIL

Rail shall be control cooled new or minimum Class 1 relay according to the AREMA manual for wear, with a minimum section of 130 pounds/yard. **Deviations from this requirement need written approval from the Company.**

Rail should be furnished in lengths not less than 31 feet and should be drilled to accept the proper size joint bars for the section of rail being used.

If welded rail is used, the type of welding should have approval of the Company's Chief Engineer or his representative.

Rails should be laid one at a time. The bottom of the rail and the bearing surface of the tie plate should be cleaned of all debris before the rail is laid. Joints in opposite rails shall be staggered not less than 8 feet and not more than 14 feet apart, except as close joints may be required at insulated joints or turnouts. To minimize the cutting of full length rails, short rails of not less than 15 feet may be used in adjusting for proper spacing of joints. Proper allowance for expansion should be provided at rail joints by installing rail expansion shims conforming to the section of rail being used.

When necessary to cut and/or drill a rail, it should be cut with an approved rail saw, and drilled with an approved rail drill. **Flame cutting of rail will not be permitted.**

TURNOUTS

Turnouts shall be control cooled new or minimum Class 1 relay according to the AREMA manual for wear, with a minimum section of 130 pounds/yard. **Deviations from this requirement need written approval from the Company.** The turnouts shall be the size and shape as called for on the plans and shall meet all requirements in accordance with an approved design, AREMA , or equal. The turnout material shall be complete in every respect to construct the needed turnouts ready to receive train traffic. Package switches shall be of an approved design. AREMA, or equal, equipped with standard reinforced points and of correct length for the size of turnout of which they are a part. Frogs shall be of an appropriate design, AREMA, or equal, equipped with plates of the proper size and type to fit the designed track layout. Frogs in main tracks shall be No. 10 or larger and frogs in sidetracks shall be No. 10 unless space will not permit, in which case the use of a No. 8 will be considered. Where the Company has plans to upgrade the parent track, then the rail and frog section shall be as required by the Company. Reference Standard Plan No: RBMN 6-0 for turnout geometry. Standard No.8 and No. 10 turnouts are shown on Plan No: RBMN 4-0 and RBMN 5-0 attached. All turnouts in tracks to be used by the Company shall have easy throw handles and standard Reading Blue Mountain & Northern Railroad targets and signs installed as shown in Sign Diagram Nos. 20-0, 21-0 and 22-0 attached. **ALL switch targets and applicable signage must be purchased from the Company for a fee.**

CROSSTIES

Crossties should be new and conform to Reading Blue Mountain & Northern Railroad specification for 6" X 8" X 8' 6" – Grade 3, 7" x 8" x 8' 6" – Grade 4 or 7" x 9" x 8' 6" – Grade 5 for oak and mixed hardwood ties. All ties shall be air dried to a maximum to 50% moisture content for oak and 40% for mixed hardwoods before treatment.

The ties must be sterilized during treatment by holding them in 190°- 210°F temperature creosote for at least 6 hours. This time shall not include creosote filing

or emptying, not temperature adjustments or final vacuum time. Final retentions shall be 8#/CF in oak and 10#/CF for mixed hardwoods.

Except as noted above, all treatment shall be governed by American Wood-Preservers' Association Standards C1, C6, M1, M3, and M4. A 60/49 creosote-coal tar solution conforming to AWPAs Standard P-2 shall be used. The solution shall be tested according to AWPAs Standard A-1.

Certification of the ties must be furnished from the contractor and/or supplier based on Reading Blue Mountain & Northern Railroad specifications.

Crossties shall be placed on the prepared subballast at right angles or normal to the centerline of the track. Crossties shall be spaced 20 inches, center to center (60 ties per 100 feet) with the ends of the ties along one side of the centerline on tangent track and along the inside on curved track being placed 18 ½" from the base of rail.

SWITCH TIES

Switch ties shall be new oak and mixed hardwood ties of 7" x 9" in cross section and in 12" length increments as required for the turnout being used. All switch ties shall be air-dried and treated as called for in Article 6.05 "Crossties". No second hand switch ties may be used.

Switch ties will be used to the point where cross ties can be end butted. No interlacing of ties is permitted.

TIE PLATES

Tie plates should be new or second hand, of good quality and of an approved design for the weight of rail to be used. Two tie plates per tie, under the base of rail must be used. Also, tie plates must be used on all switch ties not protected by switch plates, frog plates or guard rail plates.

The tie plates shall be double shouldered and have a minimum size of 7 ½" x 11" with proper punching to fit the base of the rail being used. The down slope (1:40 cant) of the tie plate shall be directly over and parallel with the centerline of the crosstie. The tie plate shall be set so that the outside shoulder of the tie plate shall bear squarely against the base of the rail, having a full bearing for the rail and at the same time, a full bearing on the crosstie.

RAIL JOINTS

Joints should be either new or No. 1 relay and of the size, drilling and hole spacing to fit the rail being used.

Joint bars should be properly installed **with the full number of and the correct size of bolts, nuts and spring washers.** Bolts shall be placed with nuts alternately on inside and outside of rail and shall be drawn tight before spiking. Bolts shall be tightened by the use of approved track wrenches or track bolt machines. **All lockwashers must be installed and flat.**

All joints shall be kept out of grade crossings with no joint be closer than 10 feet from the edge of the crossing.

All compromise joints must be welded when different size rails are to be connected.

BOLTS AND NUTS

Bolts and nuts for the track and turnouts should be new or approved relay and of the correct diameter and length to fit the rail and joints being used. Bolts and nuts must conform to the latest AREMA specifications.

LOCK WASHERS

Lock washers should be new and of correct diameter to fit the bolts being used. Each track bolt should be equipped with a spring lock washer, conforming to the most current AREMA Specifications for Spring Washers.

RAIL ANCHORS (JOINTED RAIL)

Rail anchors should be new or relay of good quality and should be the correct size and of approved design for the rail used. Anchors should be applied so as to box anchor every fourth tie, i.e., the number of anchors shall be equal to the number of ties. Rail anchors should be installed through the turnouts in accordance with the Standard Plan for the turnout being used. Rail anchors to be used on tracks to be owned by the Company shall conform to Reading Blue Mountain & Northern Railroad specifications and be purchased from a Reading Blue Mountain & Northern Railroad approved supplier.

TRACK SPIKES

Only standard, new 5.8" x 6" track spikes should be used and should conform to the most current AREMA Specifications for Low Carbon Steel Track Spikes. A minimum of two spikes per tie plate is required on tangent track. Spikes through the turnout should be applied in the number and location required in accordance with the Standard Plan attached for the turnout(s) being used. Track spikes to be used on tracks to be owned by the Company shall conform to Reading Blue Mountain & Northern Railroad specifications and be purchased from a Reading Blue Mountain & Northern Railroad approved supplier.

The spiking pattern for curves should be in accordance with the anchor and double spiking of curves diagram (see attachment Plan No. RBMN 12-0).

DRIVE SCREW SPIKES

New 7/8" x 7" drive screw spikes should be used for turnouts in accordance with the Standard Plan for the turnout(s) being used.

New drive screw spikes of appropriate size shall be used for grade crossings in accordance with Plan No. RBMN 13-0, Plan No. RBMN 14-0, and Plan No. RBMN 1-0 attached to these guidelines.

DERAILS

Single switch point derails are required on all industry sidings. Where double switch point derails are required they must be installed in accordance with the attached Standard Plan for Derails, Plan No: RBMN 7-0. They must be sized to fit the rail and thrown with an operating stand equipped with an ergonomic bow handled throwing lever (see attached Plan No. RBMN 8-0, Bow Handled Throwing Lever). Care must be taken when installing derails to insure that they are installed properly to keep derailed cars from fouling the main track. Standard Reading Blue Mountain & Northern Railroad target and derail signs must be installed as shown in Sign Diagram Nos. 20-0, 21-0 and 22-0 attached. **ALL switch targets and applicable signage must be purchased from the Company for a fee.**

BUMPING POSTS, WHEEL STOPS, AND EARTH MOUNDS

Bumping posts, wheel stops, or earth mounds shall be placed at the open end of all stub-ended tracks. Bumping posts and wheel stops shall be either new or secondhand, of good quality and approved design. Earth mounds (see attached

Plan No. RBMN 15-0) should be of an approved design sufficient to stop a moving car and should be protected against erosion. Bumping posts will be used on all stub end tracks which end at a structure, dock, road or where public or private safety is required.

Where no factors exist to require bumping posts, earth mounds or wheel stops may be constructed.

The Industry shall provide a “minimum” half car of vacant space or distance between the last car spot and the end of track device.

SWITCH POINT PROTECTORS

Depending on amount of traffic through turnouts and/or location of turnouts, switch point protectors should be installed. Where needed, these protectors should be new or secondhand, of good quality and should be compatible with the size and type of switch point being used. The design for switch point protectors to be used on turnouts to be owned by the Company shall be approved by Reading Blue Mountain & Northern Railroad.

FROG GUARD RAILS

Guard rails must be installed for all frogs. They should be new or No. 1 Relay Hook-flange style. **Deviations from this requirement need written approval from the Company.**

SWITCH STANDS

Switch stands must be installed for each turnout. Reading Blue Mountain & Northern Railroad recommends using a New Century Model 51-A switch stand equipped with an ergonomic bow handled throwing lever (see attached Plan No. RBMN 8-0, Bow Handled Throwing Lever). All switch stands should be complete in every respect and throw rods adjusted for proper throw, including grinding of stock rails if such is necessary for positive closure of switch point against stock rail.

Switch stands and latches shall be securely fastened to head block ties using $\frac{3}{4}$ "x6" lag screws. Switch stand cranks must be made of forged steel. Switches shall be equipped with standard Reading Blue Mountain & Northern Railroad targets and green signs. Switch targets and applicable signage to be purchased from the Company for a fee. **Switches on main tracks must be electronically locked or in dark territory must have point locks.**

SECTION 5 - GENERAL CONSTRUCTION AND REHABILITATION REQUIREMENTS

CONSTRUCTION

Industry track shall be constructed with a gage of four feet eight and one half inches (4' 8 ½") on tangents and curves. All track shall be constructed to the alignment of grades shown on the approved plans and will meet Federal Railroad Administration (FRA) Class 4 requirements for track surface.

No track or turnout shall be placed on the roadbed, until the finished subballast has been approved. All track and turnout materials should be handled in such a manner to protect such materials from being damaged. The alignment of the centerline of the track and the locations of turnouts should conform to that shown on the approved plans and further defined by an on-the-ground staked location.

REHABILITATION

Industry tracks that are in place and need rehabilitation will be upgraded to meet Federal Railroad Administration Class 2 requirements for crosstie condition and track surface.

All ties will be installed to a gage of four feet eight and one half inches (4-8 1/2") plus or minus ¼" on tangents and curves. Ties must be double tamped tight against the rail mechanically and the cribs full with ballast. All joints are to be tightened and bolts to be replaced with the correct size as required. If gaging of track is required spikes will be pulled on the low side, tie plugged and respiked per specifications. All other requirements of Section 4 – Materials, must be satisfied unless written permission was received from the Company to deviate from the specification.

The final step for rehabilitation and construction of track or turnouts should be the removing of all waste and rubbish from the track project site. The track project should not be considered complete until clean up of the work site is accomplished.

It should be understood that final approval of the track for service is the prerogative of the Company, and close contact with the Company supervisory officials is desirable. No work is to be performed on Reading Blue Mountain & Northern Railroad tracks by Contract forces, or in such proximity as to interfere with the Company's tracks or roadbed without explicit permission of the Company.

Upon completion of the project, the Industry must fax a request for inspection to the Company's Maintenance of Way office at (610) 562-3707. If more than one inspection is required, the Industry will be charged a fee of \$600.00 for each additional inspection.

SECTION 6 - CROSSINGS

GRADE CROSSINGS

The following grade crossing surface types are recommended for installation depending on the crossing location, traffic type and traffic density.

- Full Timber
- Timber and Asphalt
- Rubber Rail Seal
- Precast Concrete
- Cast in Place Concrete

Grade crossings should be used as little as possible. Where grade crossing are to be installed on the plans, prior approval of the surface type must be provided by the Company.

For proposed Industry tracks on railroad property or roads parallel to existing Company tracks, the Industry must submit complete plans to the Company for approval to permit construction. **All private grade crossings or roads parallel to Industry tracks must meet Company standards and will be covered under an operating agreement.**

SECTION 7 - BRIDGES, TRESTLES, BOX CULVERTS AND UNLOADING PITS

GENERAL

All proposed bridges, trestles, box culverts, unloading pits and structures over which the Company's equipment will operate shall be designed in accordance with American Railway Engineering and Maintenance-of-Way Association (AREMA) Manual for Railway Engineering, Chapters 7 (Timber), 8 (Concrete), and 15 (Steel Structures), for E80 Live Loading and appropriate impact. Prior to the beginning of construction, the proposed design must be approved by the Company's Chief Engineer – Bridges and Structures. Sufficient time should be allowed for proper review and approval.

The Chief Engineer – Bridges and Structures, shall approve drawings covering temporary sheeting and bulkheads to protect railroad tracks during adjacent structure construction.

Clearances and drainage requirements will be furnished upon request to the Chief Engineer-Bridges and Structures.

UNLOADING PITS

The following guidelines shall be used when designing all unloading pits.

There shall be no rail joints in the running rail over the pit. Welding and torch cutting of running rail shall not be permitted.

The top of the pit shall be equipped with a removable cover which will be kept in place when the pit is not in use and which shall be designed in accordance with AREMA Chapter 15, Section 8.5.3.2.

Minimum distance from centerline of any adjacent track to nearest edge of pit walls is to be 15 feet. Closer clearances require special approval and indemnity if permitted.

Minimum horizontal distance from centerline of pit track to adjacent obstructions above the top of the pit is to be 9 feet (see Plan No: RBMN 11-0).

Pit cover and top of pit are to extend a minimum of 10 feet from the centerline of pit track on open side of pit. Embankment side slopes should not be steeper than 2 to 1.

Applicant is to furnish the distance and direction from centerline of pit to nearest switch point and to the switch point at the mainline. Application, plans, and details of each pit are to be submitted to the Division Superintendent and are to be approved before construction may begin.

SINGLE SPAN UNLOADING PITS WITH A SPAN LENGTH OF 15 FEET OR LESS

Live Load: Coopers E-80 with 28 percent impact.

Design specifications and workmanship shall be in accordance with current AREMA Specification, Chapters 7 (Timber), 8 (Concrete), and 15 (Steel Structures).

General pit details can be referenced from Figures 8-5, 8-6, and 8-7 in the AREMA Manual Chapter 15, Section 8. However, Reading Blue Mountain & Northern -

Railroad requires that the top of pit to extend a minimum of 10 feet from the centerline of the pit track, the not eight feet shown by AREMA in Figure 8-5.

SINGLE SPAN UNLOADING PITS WITH A SPAN LENGTH GREATER THAN 15 FEET OR MULTI-SPAN PITS

General

All portions of the unloading structure that are subjected to train or equipment loading shall be designed as a bridge in accordance with the AREMA Manual (current edition). All plan submittals for proposed unloading structures must include design calculations stamped by a registered professional engineer certifying that the design is in accordance with AREMA requirements. If computer programs are utilized in the design, the submittal shall include a complete summary of the input data used and all design assumptions. Additional manual calculations may be required to document compliance with AREMA requirements. Thirty days should be allowed in scheduling for the Company's review for unloading structure plans and calculations.

Steel Superstructure

Span Type: All spans shall be designed as simple spans. The use of side plates, bolted to beam webs, will be permitted as a means to stabilize or maintain alignment between adjacent spans. All beam ends shall have bearing stiffeners and shall bear directly on pit walls, floor beams or columns. Attachment of ends of floor beams to vertical steel plates, embedded in pit wall is prohibited.

Loadings: All steel superstructure shall be designed for Cooper E-80 live loading and appropriate impact. ALL loads outlined in Section 1.3 of AREMA Chapter 15 must be considered in the design. A reduction in wind load (Section 1.3.7) may be considered where justified by local conditions. To the extent possible, hoppers and mechanical features of the unloading structure should be supported independent of the superstructure carrying train loading.

Fatigue: By AREMA definition, all rail support beams and floor beams are fracture critical members and must be so designated on the plans. The steel superstructure shall be designed to include fatigue consideration for 2,000,000 cycles and allowable stresses reduced, based on the fabrication and connection details used. All material specifications, including notch toughness requirements, must be shown on plans. All non-destructive testing requirements shall be shown on the plans. When requested to do so, the Industry or its designated representative will furnish the Company with copies of material certifications and test results, as well as copies of results of testing required during fabrication.

Erection: The steel superstructure supporting train loading shall be shipped, handled and erected in such manner as to avoid injurious bends, nicks or gouges to the steel. Field welding may be used only for minor connections, not subject to train live load force, as outlined in Section 1.5.10 of AREMA Chapter 15.

Concrete Substructure: All concrete portions of under track unloading structures that are subjected to train loading shall be designed in accordance with Chapter 8 of the AREMA Manual. Pit end walls shall be designed for the effects of vertical load from rail support beams and live load surcharge from train on ground track adjacent to the pit. Surcharge from adjacent parallel tracks, roadways and buildings shall be considered in the design of pit side walls. Calculation and application of train surcharge loadings shall be as outlined in AREMA Chapter 8.

Foundations: Submittal of unloading structure plans shall include a geotechnical report defining the characteristics of the soils at the site and their suitability for supporting the

design loads. All foundations for unloading structures shall be designed in accordance with the requirements in AREMA Chapter 8.

Approach Walls: If approaches to the main pit span or spans, are to be constructed of parallel reinforced concrete walls, with the rails attached directly to the top of the walls, the approach walls shall be designed in accord with AREMA Chapter 8, Concrete Structures and Foundations. The two parallel walls shall have a single footing supporting both walls. Where necessary to obtain safe bearing capacity, the approach walls shall extend to the same depth as the pit walls. The rails shall be attached to the walls using standard Pandrol plates and clips, unless other attachment is approved by the Chief Engineer – Bridges and Structures. Pandrol plates and clips shall be spaced at 2'0" maximum.

SECTION 8 - SCALES

GENERAL

All proposed scales over which the Company's equipment will operate or where an industry will request a weight agreement using their scale for assessment of freight haulage charges shall be designed in accordance with Section IX and also Chapter 34 of the American Railway Engineering and Maintenance-of-Way Association (AREMA) Manual For Railway Engineering. Proposed design plans must be submitted and approved prior to beginning construction.

PLANS

Plans are to be submitted to:

Chief Engineer – Bridges and Structures

Reading Blue Mountain & Northern Railroad PO Box 218

Port Clinton, PA 19549

Plans must include, as a minimum, the following:

- Site plan showing scale and instrument building location with track elevations and distances to points of curvature.

- Plans must be stamped with Industry's name and location.

- Plans must include complete structural detail with calculations.

- Nation Type Evaluation Program (NTEP) Certificates of Conformance (COC) for Load Cells, Instrumentation and Weigh Bridge.

OTHER REQUIREMENTS

Scales must meet requirements of National Institute of Standards & Technology (NIST) Handbook 44 and all other local, State and Federal requirements.

SECTION 9 - HAZARDOUS COMMODITIES

GENERAL

Rules and regulations governing the location of new loading, unloading and storage facilities for flammable liquids, combustible liquids, pyrophoric liquids, compressed gasses and other hazardous commodities on System Lines will be considered on an individual basis upon application by Industry to the Company.

APPLICATION PROCEDURE

Applications for location or relocation of facilities for loading, unloading or storage of flammable liquids, combustible liquids, pyrophoric liquids, compressed gasses and other hazardous commodities, must be submitted to the Division Superintendent.

To expedite handling of such applications, it is essential that all available facts be contained in the application and accompanied by a detailed print. Bear in mind these regulations are the minimum. Safety is foremost. Each application must be considered on its merits and factors, such as exposures to high valued property and density of traffic adjacent to unloading and storage points.

In no case will hazardous materials or contaminants be allowed to drain on Company property or be carried in Company drainage systems.

STORAGE OF HAZARDOUS MATERIALS

Table 11.03.1 Separation Distance for New Facilities
Loaded Tank Cars and Storage Tanks from Mainline

ACTIVITY	COMBUSTIBLE LIQUID CORROSIVE MATERIAL OR ORM'S	PIH (HAZARD ZONE A OR B) FLAMMABLE LIQUID, FLAMMABLE GAS, NON FLAMMABLE GAS AND ALL OTHER HAZARD CLASSES
Loading and Unloading	50 FEET	100 FEET
Loaded Tank Car Storage	25 FEET	50 FEET
Storage in Tanks	50 FEET	100 FEET

NOTE: Above distances are centerline of rail to centerline of rail and/or centerline of rail to closest part of structure.

Definitions:

ORM – (Oxidized and Radioactive Material) | PIH – (Poisonous Inhalation Hazard)

With regard to existing facilities, maximum reasonable effort must be made to conform to this standard by taking into consideration cost, physical and legal constraints.

The proposals apply to storage on Company property and on Industry property located close to railroad mainline.

SECTION 10 – END OF MAINTENANCE SIGNAGE

SIDETRACK OFF FACILITIES

End of Maintenance Signs installed on Sidetrack OFF Facilities will be installed at the property line.

End of Maintenance Sign will be installed ten feet from edge of rail and ten feet high on RBMN property.

SIDETRACK ON FACILITIES

End of Maintenance Signs installed on Sidetrack ON Facilities will be installed forty feet from the frog.

End of Maintenance Sign will be installed ten feet from edge of rail and ten feet high on RBMN property.

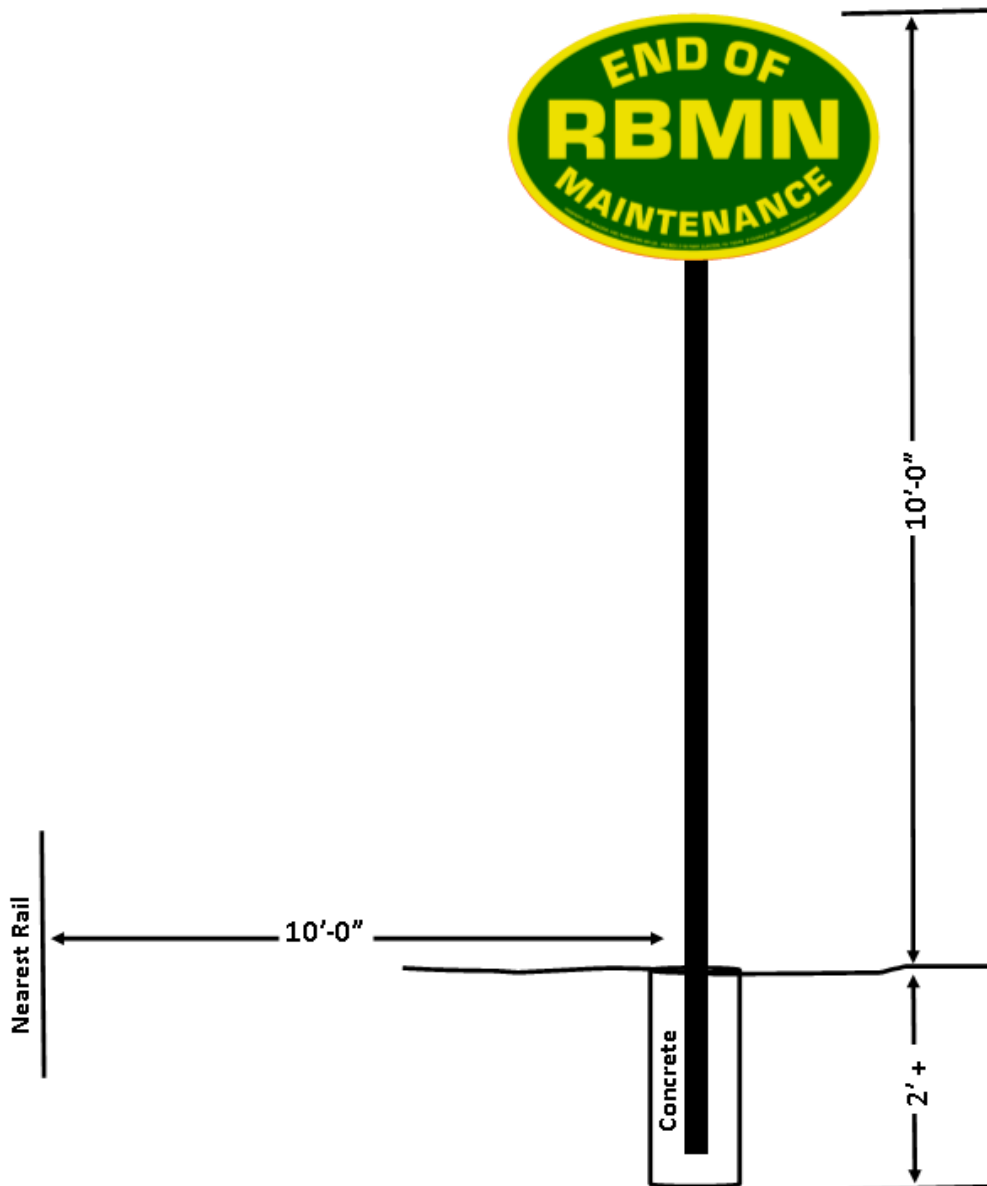

SPIKES

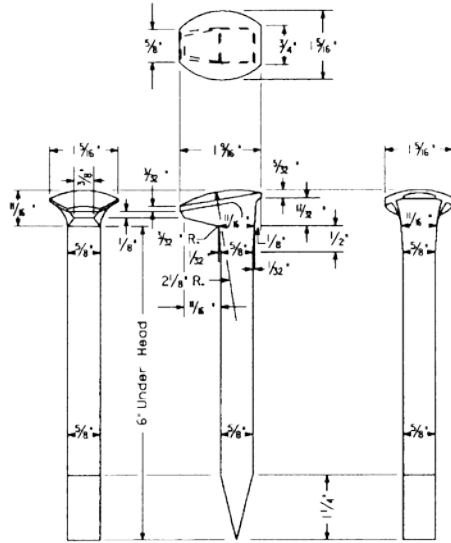

5/8" X 6" CUT TRACK SPIKE

A.R.E.A. STANDARD
To conform to A.R.E.A. Specifications
for Soft Steel Cut Spikes.
Weight Per Spike = 0.8197*
244 Spikes Per 200* Keg
640-903705

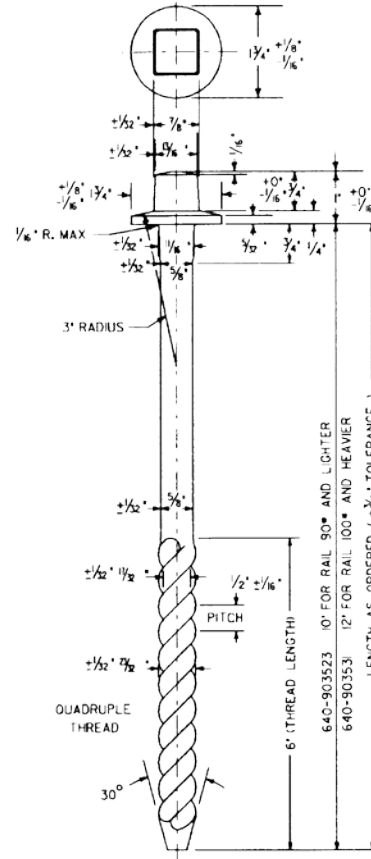

5/8" GALVANIZED DRIVE SCREW SPIKE
A.R.E.A. STANDARD
PLAN 2M-63

For fastening Crossing Timbers
Drill 1/2" pilot hole in cross-ties
10" Length for use with rail 90* R.A. and lighter
125 Spikes per 200* Keg
12" Length for use with rail 100* R.E. and heavier
100 Spikes per 200* Keg

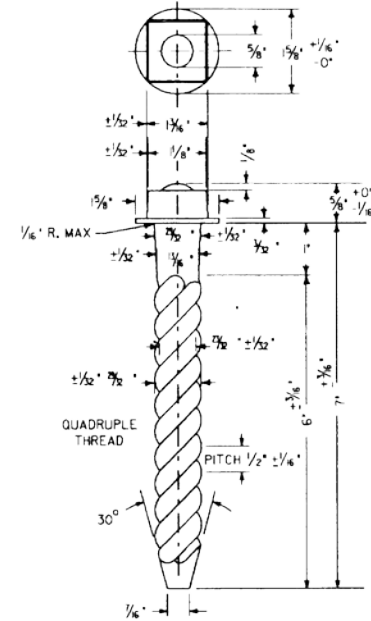

7/8" X 7" GALVANIZED DRIVE SCREW SPIKE
A.R.E.A. STANDARD

For use where specified in Turnouts
Drill 1/2" pilot hole
150 Spikes per 200* Keg
640-903565

READING BLUE MOUNTAIN AND NORTHERN RAILROAD
ENGINEERING AND INDUSTRIAL DEVELOPMENT DEPARTMENTS

PLAN NO: RBMN 1-0

ROADBED SECTION HEAVY TONNAGE TRACKS

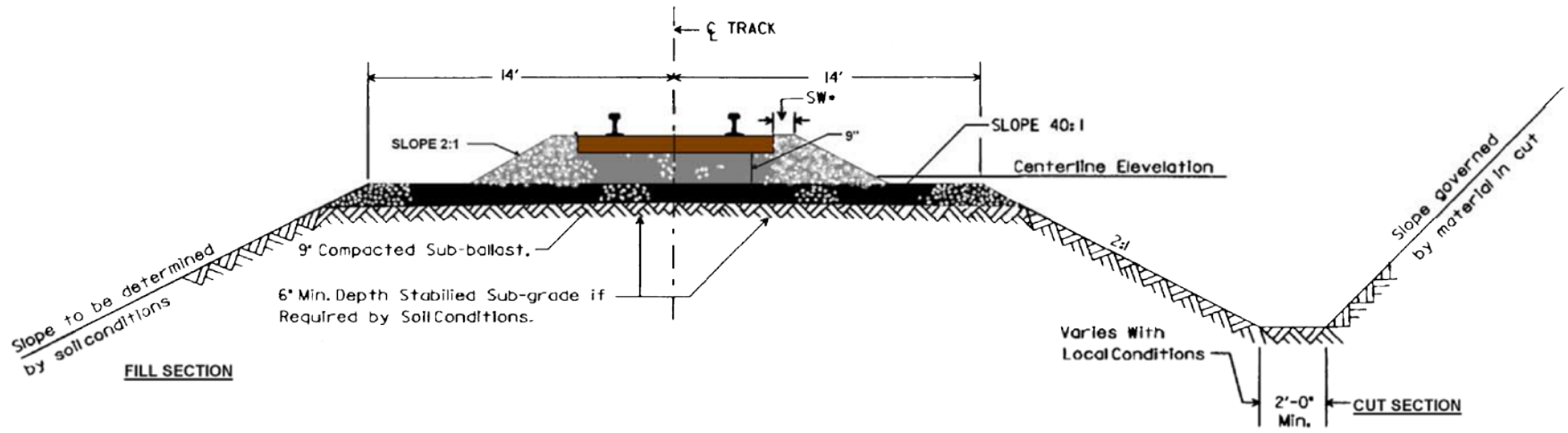

SHOULDER WIDTH (SW*)

BALLAST WIDTH FROM END OF TIE TO EDGE OF SLOPE

	<u>Jointed Rail</u>	<u>Welded Rail</u>
SW –Inside of Curve	0"	6"
SW-Outside of Curve	6"	12"
SW-Tangent both sides	0"	6"

- (1) Sub-grade may be stabilized with lime, lime-fly ash, cement or stone.
- (2) Tamping of ballast must not disturb compacted sub-ballast.
- (3) Top of sub-grade is to be crowned.

READING BLUE MOUNTAIN AND NORTHERN RAILROAD
ENGINEERING AND INDUSTRIAL DEVELOPMENT DEPARTMENTS

PLAN NO: RBMN 2-0

ROADBED SECTION FOR INDUSTRIAL TRACKS

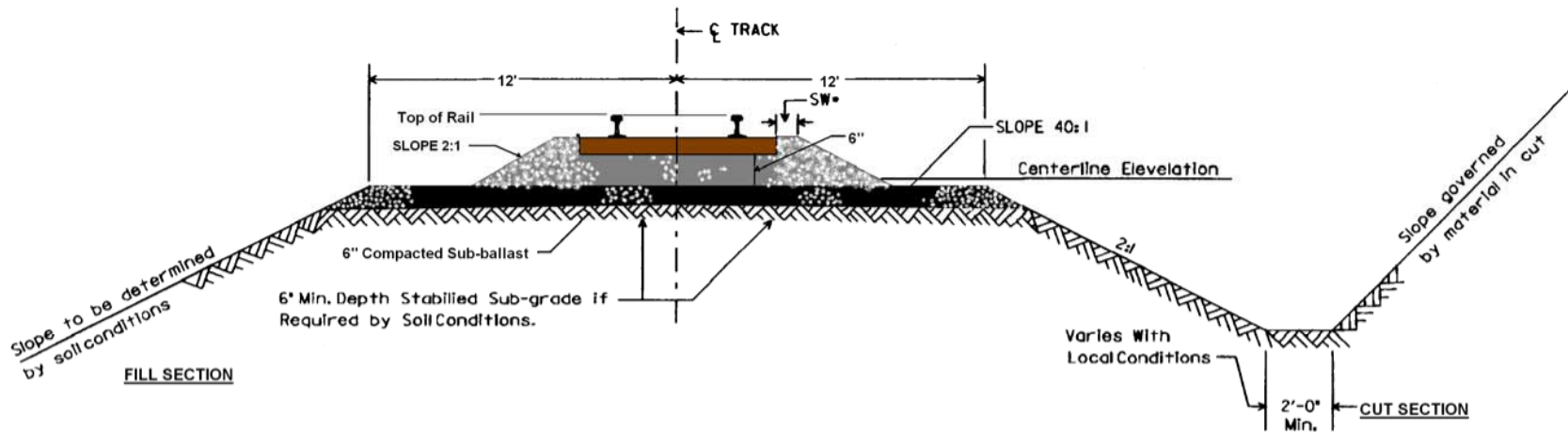

- (1) Sub-grade may be stabilized with lime, lime-fly ash, cement or stone
- (2) Tamping of ballast must not disturb compacted sub-ballast.
- (3) Top of sub-grade is to be crowned.

READING BLUE MOUNTAIN AND NORTHERN RAILROAD
ENGINEERING AND INDUSTRIAL DEVELOPMENT DEPARTMENTS

PLAN NO: RBMN 3-0

No. 8 132/136 RE TURNOUT

WITH 16'-6" SWITCH, S.M.S.G. FROG AND SWITCH POINT GUARD

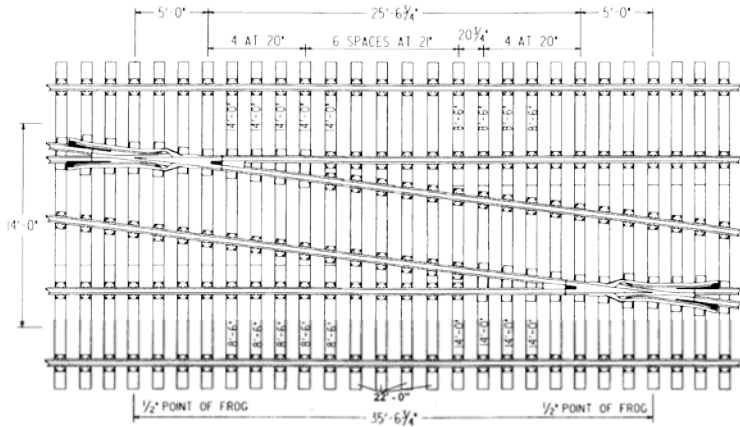

**SEE PLAN 1-4 BOLTS USED IN TRACKWORK
TIES 7"X9"**

BILL OF SWITCH

	<u>No. of Pieces</u>	<u>Length</u>
3-6 16'-6" SWITCH	11	9'-0"
3-15 SWITCH HEEL BLOCK	12	10'-0"
3-16 SWITCH HEEL BASE PLATE	6	11'-0"
3-19 SWITCH LUGS (CLIPS)	6	12'-0"
3-20 SWITCH RODS	4	13'-0"
3-21 SWITCH PLATES	6	14'-0"
3-22 ADJUSTABLE PLATES & BRACES	6	15'-0"
3-23 3/4" AND 1" GAUGE PLATE	6	16'-0"
3-34 AND 3-35 SWITCH STANDS		
4-9 SMSG FROG		
4-11 FROG PLATES FOR SMSG FROGS		

CROSSOVER

14' TRACK CENTERS - LENGTH 163'-71/8"

NO. 8 TURNOUT

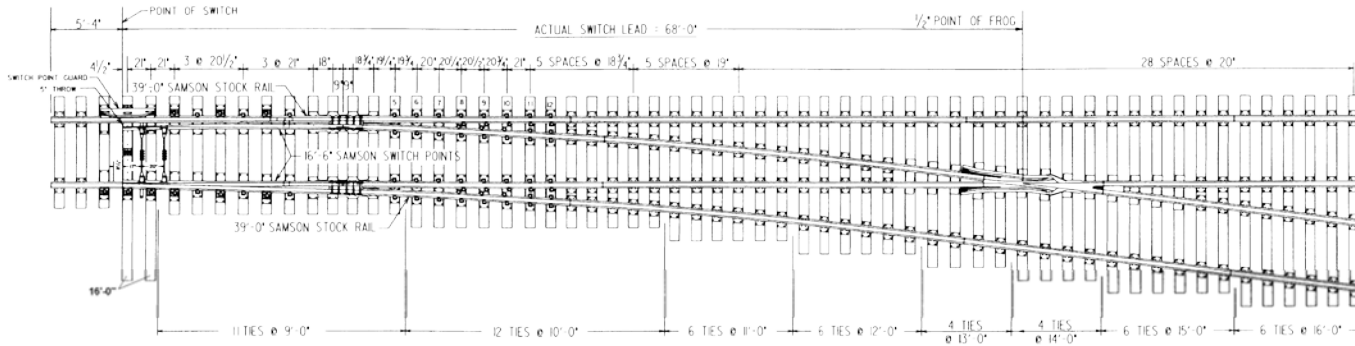

CROSSOVER DATA FOR TANGENT TRACK CENTERS BETWEEN 1/2" PTS

TRACK CENTERS	DISTANCE BETWEEN 1/2" PTS
13'-0"	27'-7 1/8"
14'-0"	35'-6 3/4"
15'-0"	43'-6 3/8"
16'-0"	51'-6"
17'-0"	59'-5 5/8"
18'-0"	67'-5 1/4"
19'-0"	75'-4 7/8"
20'-0"	83'-4 1/2"

OFFSET DIAGRAM

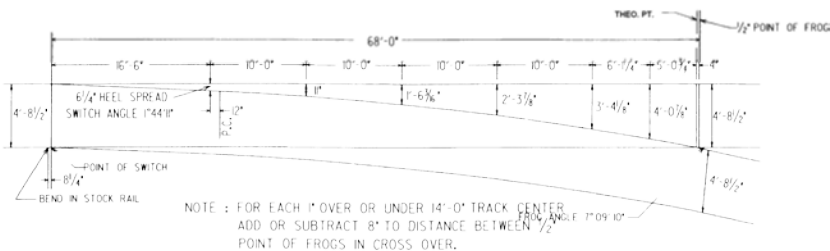

NOTE : FOR EACH 1" OVER OR UNDER 14'-0" TRACK CENTER
ADD OR SUBTRACT 8" TO DISTANCE BETWEEN 1/2"
POINT OF FROGS IN CROSS OVER.

**READING BLUE MOUNTAIN AND NORTHERN RAILROAD
ENGINEERING AND INDUSTRIAL DEVELOPMENT DEPARTMENTS**

PLAN NO: RBMN 4-0

No. 10 132/136 RE TURNOUT WITH 16'-6" SWITCH and RAIL BOUND MANGANESE FROG

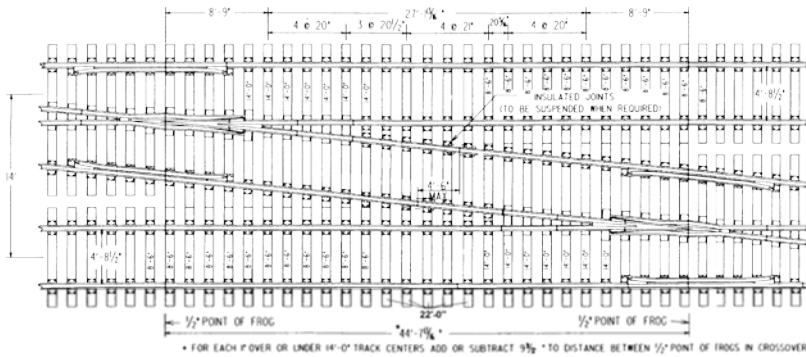

- SEE PLAN 1-4 BOLTS USED IN TRACKWORK**
- 3-7 16'-6" WELDED SWITCH
 - 3-19 SWITCH LUGS (CLIPS)
 - 3-20 SWITCH RODS
 - 3-21 SWITCH PLATE DETAILS
 - 3-22 ADJUSTABLE BRACE PLATE DETAILS
 - 3-32 TO 3-35 SWITCH STANDS
 - 3-22 ADJUSTABLE PLATES & BRACES
 - 4-14 RAIL BOUND MANGANESE FROGS
 - 4-19 FROG PLATE DETAILS

BILL OF SWITCH TIES 7"X9"

No. of Pieces	Length
11	9'-0"
14	10'-0"
9	11'-0"
6	12'-0"
6	13'-0"
8	14'-0"
6	15'-0"
8	16'-0"

CROSSOVER

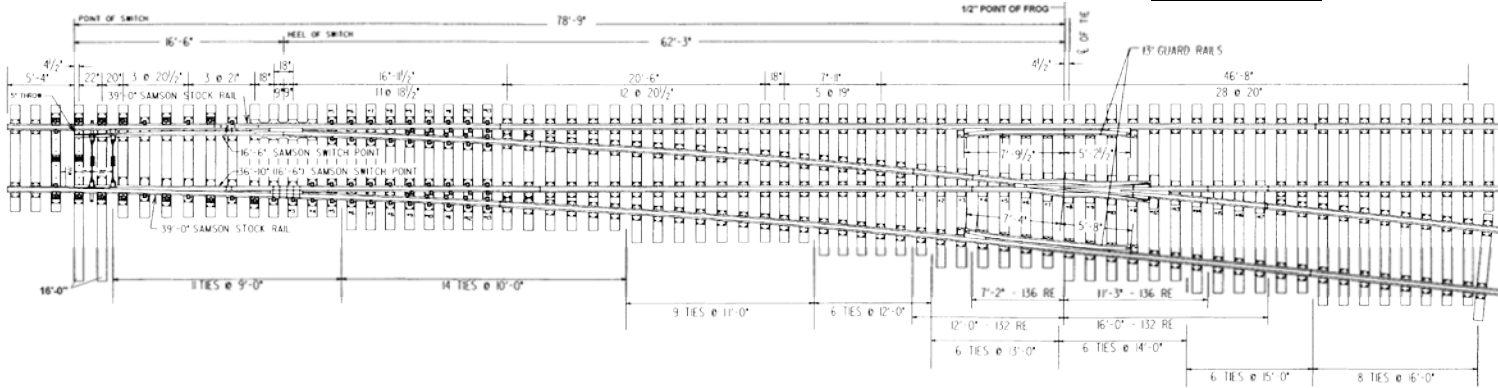

**CROSSOVER DATA
FOR TANGENT TRACK
TRACK DISTANCE
CENTERS BETWEEN 1/2" PTS**

13'-0"	34'-8 1/8"
14'-0"	44'-7 13/16"
15'-0"	54'-7 1/2"
16'-0"	64'-7 3/16"
17'-0"	74'-6 7/8"
18'-0"	84'-6 9/16"
19'-0"	94'-6 1/4"
20'-0"	104'-5 15/16"

NO. 10 TURNOUT

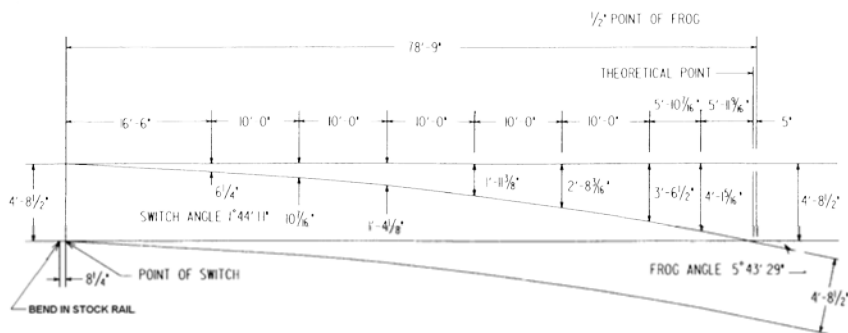

OFFSET DIAGRAM

READING BLUE MOUNTAIN AND NORTHERN RAILROAD
ENGINEERING AND INDUSTRIAL DEVELOPMENT DEPARTMENT

PLAN NO: RBMN 5-0

DATA ON TURNOUTS AND CROSSOVERS

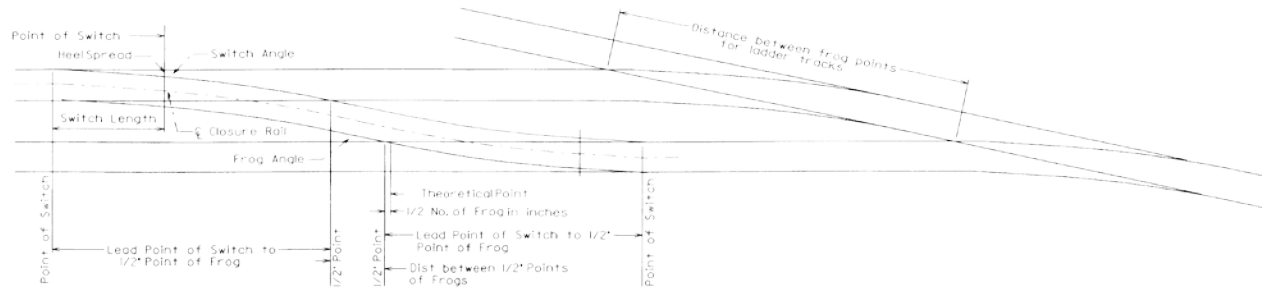

FROG NO.	L POINT OF SWITCH TO 1/2 POINT OF FROG	C° DEGREE OF CURVE & CLOSURE RAILS	TURNOUT						A P.S. TO INT. PT.	B I.P. TO 1/2 PT. FROG	D 1/2 P.F. P.C. RET. CURVE	E TANG. RET. CURVE TO INT. PT.	T.L. I.P. TO P.I. RET. CURVE 14'-0" T.C.	C ₂ ° DEGREE RET. CURVE	C.L. CLEAR LENGTH 14'-0" T.C.	C.L. CLEAR LENGTH 15'-0" T.C.	P.S. TO 16'-0" LAST TIMBER	CROSSOVER		LADDER TRACKS		FROG NO.				
			TURNOUT PLAN NO.	FROG		SWITCH												I 14'-0"	POINT OF FROG 15'-0"	I 14'-0"	POINT OF FROG 15'-0"					
				F FROG ANGLE	FROG PLAN NO.	LENGTH	ANGLE	HEEL SPREAD															TRACK CENTERS		TRACK CENTERS	
6	47'-5"	22° 17' 58"	2-1	9° 31' 38"	4-10	11'-0"	2° 39' 34"	6 1/4"	19.00'	28.50'	34.25'	21.84'	84.58'	22° 00'	124.25'	130.21'	66'	26.42'	32.38'	84.58'	90.63'	6				
7	62'-1"	16° 31' 26"	2-2	8° 10' 16"	4-10	16'-6"	1° 44' 11"	6 1/4"	28.83'	33.25'	39.59'	25.66'	98.50'	16° 00'	152.00'	158.96'	93'	30.99'	37.96'	98.50'	105.54'	7				
8	58'-11 1/8"	10° 25' 03"	2-5	7° 09' 10"	4-10	curved 13'-0"	2° 54' 0"	6 1/4"	20.93'	38.00'	38.58'	35.86'	112.44'	10° 00'	168.35'	176.34'	84'	35.56'	43.53'	112.44'	120.47'	8				
8	68'-0"	11° 58' 03"	2-4	7° 09' 10"	4-13	16'-6"	1° 44' 11"	6 1/4"	30.00'	38.00'	44.54'	29.90'	112.44'	12° 00'	171.55'	179.43'	93'	35.56'	43.53'	112.44'	120.47'	8				
9	72'-3 1/2"	9° 43' 14"	2-6	6° 21' 35"	4-10	16'-6"	1° 44' 11"	6 1/4"	29.54'	42.75'	50.10'	33.55'	126.39'	9° 30'	188.70'	197.67'	100'	40.11'	49.08'	126.39'	135.41'	9				
10	78'-9"	7° 21' 22"	2-7	5° 43' 29"	4-14	16'-6"	1° 44' 11"	6 1/4"	31.25'	47.50'	54.63'	38.23'	140.35'	7° 30'	209.13'	219.10'	111'	44.65'	54.63'	140.35'	150.38'	10				
12	95'-4"	5° 11' 20"	2-9	4° 46' 19"	4-15	22'-0"	1° 18' 08"	6 1/4"	38.33'	57.00'	63.53'	47.76'	163.29'	5° 00'	253.80'	265.78'	129'	53.71'	65.69'	168.29'	180.31'	12				
14	106'-0"	3° 51' 39"	2-10	4° 05' 27"	4-16	22'-0"	1° 18' 08"	6 1/4"	39.50'	66.50'	78.58'	81.17'	196.25'	3° 45'	286.42'	300.40'	152'	62.76'	76.74'	196.25'	210.27'	14				
15	126'-4 1/2"	3° 19' 48"	2-11	3° 49' 06"	4-17	30'-0"	0° 57' 18"	6 1/4"	55.13'	71.25'	75.31'	63.67'	210.18'	3° 15'	328.56'	343.54'	172'	67.27'	82.26'	210.23'	225.25'	15				
20	156'-0 1/2"	1° 43' 15"	2-15	2° 51' 51"	4-18	curved 39'-0"	1° 04' 30"	6 1/4"	61.04'	95.00'	89.68'	95.50'	280.18'	1° 30'	436.36'	456.35'	220'	89.82'	109.81'	280.18'	283.47'	20				

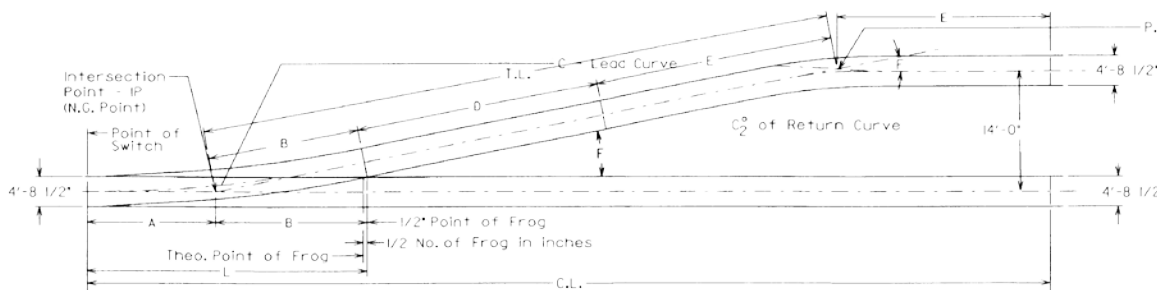

READING BLUE MOUNTAIN AND NORTHERN RAILROAD
ENGINEERING AND INDUSTRIAL DEVELOPMENT DEPARTMENTS

PLAN NO: RBMN 6-0

SWITCH POINT DERAIL

TO BE USED WHERE GRADE DESCENDS TOWARD MAIN TRACK
AND WHERE LP GAS TANK CARS ARE HANDLED

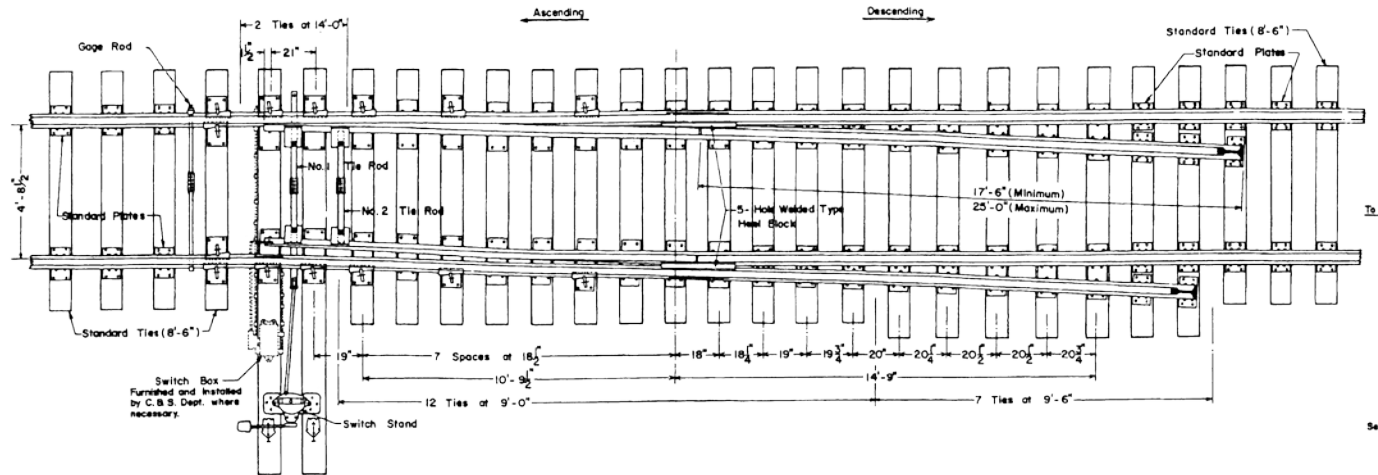

BILL OF SWITCH TIES 7" x 9"

No. of Pcs.	Length
12	9'-0"
7	9'-6"
2	14'-0"
Total No. of Pcs. 21	
Total Lin. Ft. 202.5	
Total F.B.M. 1,063	

Double Switch Point Derail -
Plan of Double Switch Point Derail shows 15'-0" switch with
switch plates spaced for No. 8 turnout, for illustration only.
Other switch material may be used where advantageous.

- See Plan 1-4 For Bolts used in Track Construction
 3-25 Thru 3-35 For Switch Heel Blocks
 3-43 For Switch Legs
 3-50 Thru 3-60 For Switch Plates
 3-61 Thru 3-64 For Adjustable Plates & Braces
 3-65 Thru 3-69 For Switch Stands

**READING BLUE MOUNTAIN AND NORTHERN RAILROAD
ENGINEERING AND INDUSTRIAL DEVELOPMENT DEPARTMENTS**

PLAN NO: RBMN 7-0

BOW HANDLED THROWING LEVER FOR 51-A & B SWITCH STAND

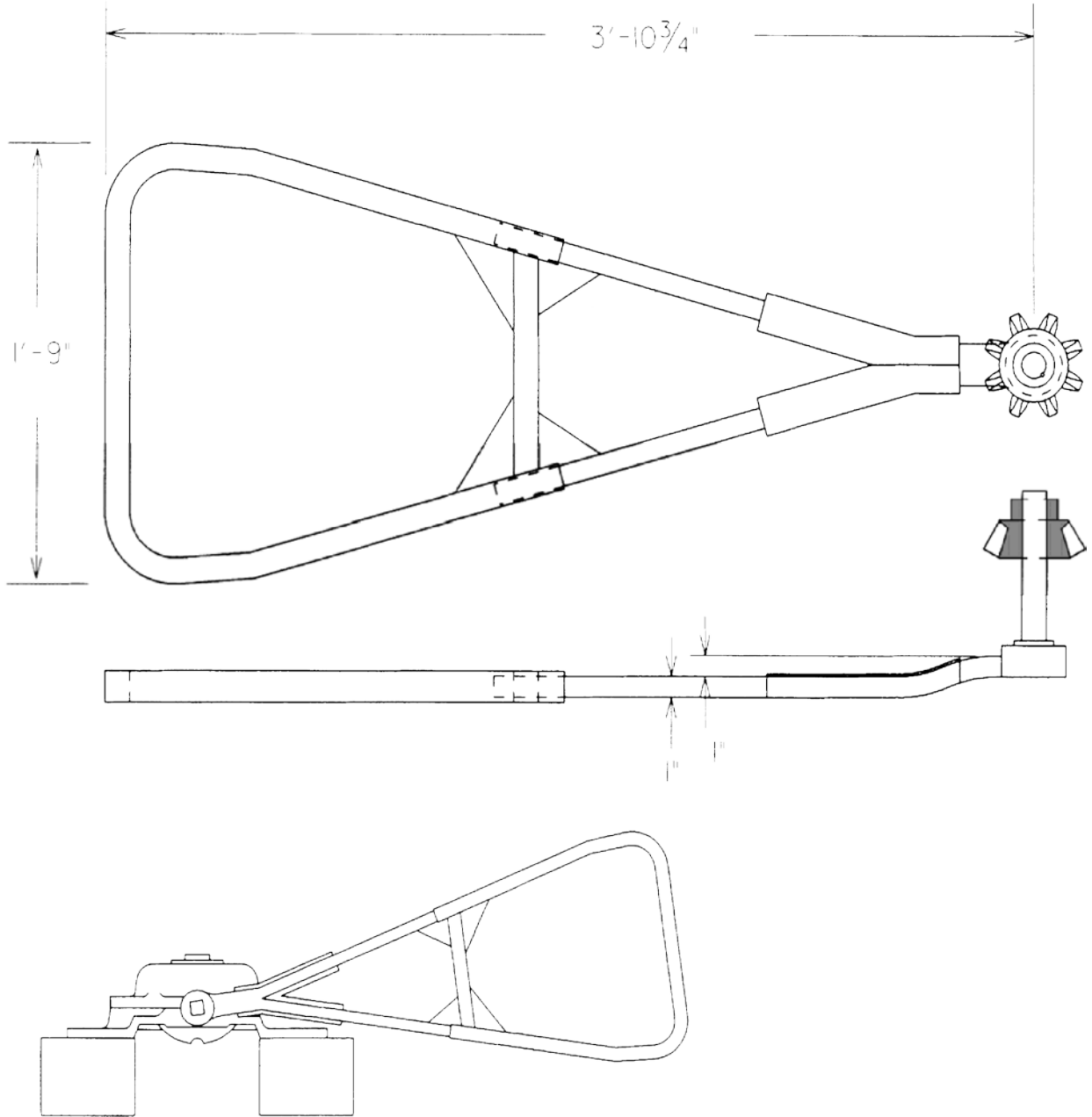

FRONT VIEW

**READING BLUE MOUNTAIN AND NORTHERN RAILROAD COMPANY
ENGINEERING AND INDUSTRIAL DEVELOPMENT DEPARTMENTS**

PLAN NO: RBMN 8-0

TURNOUT DESIGN SCHEMATIC (CENTERLINE OF TRACK REPRESENTED)

No.8 Turnout

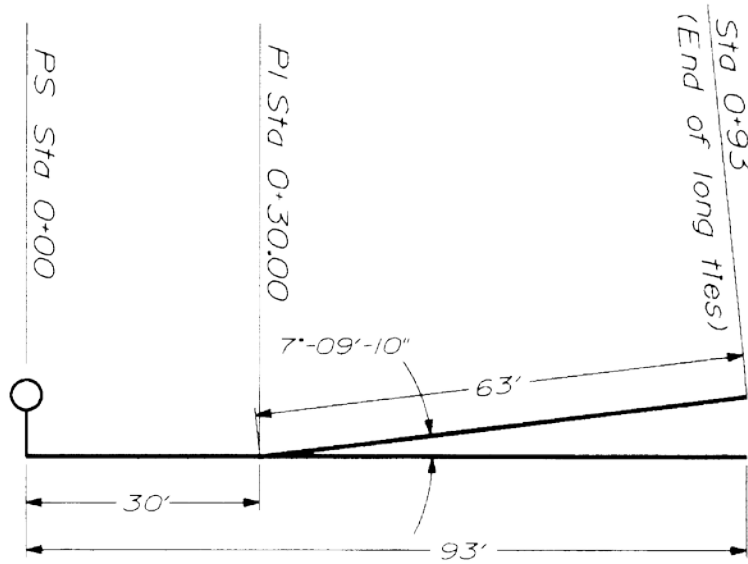

No.10 Turnout

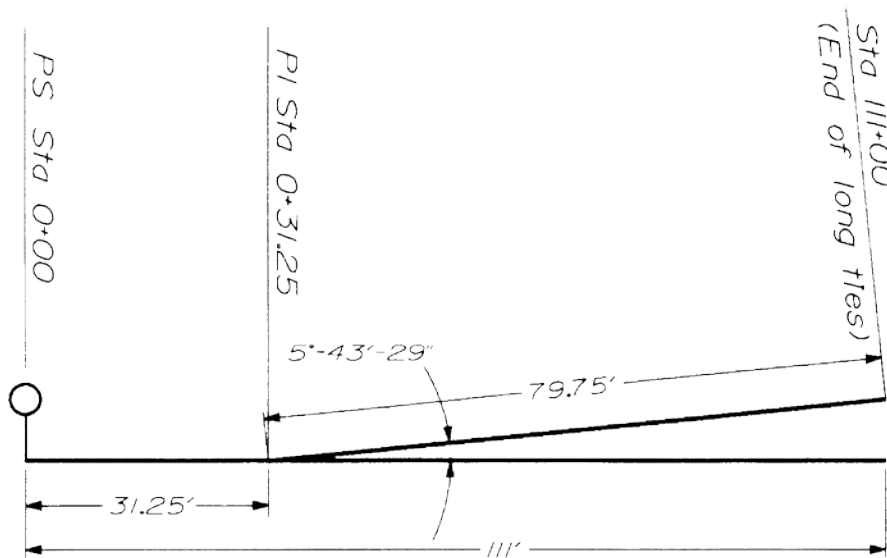

NOTE: Horizontal and Vertical curves can begin at the end of the long ties.

READING BLUE MOUNTAIN AND NORTHERN RAILROAD
ENGINEERING AND INDUSTRIAL DEVELOPMENT DEPARTMENTS

PLAN NO: RBMN 9-0

CLOSE CLEARANCE SIGN

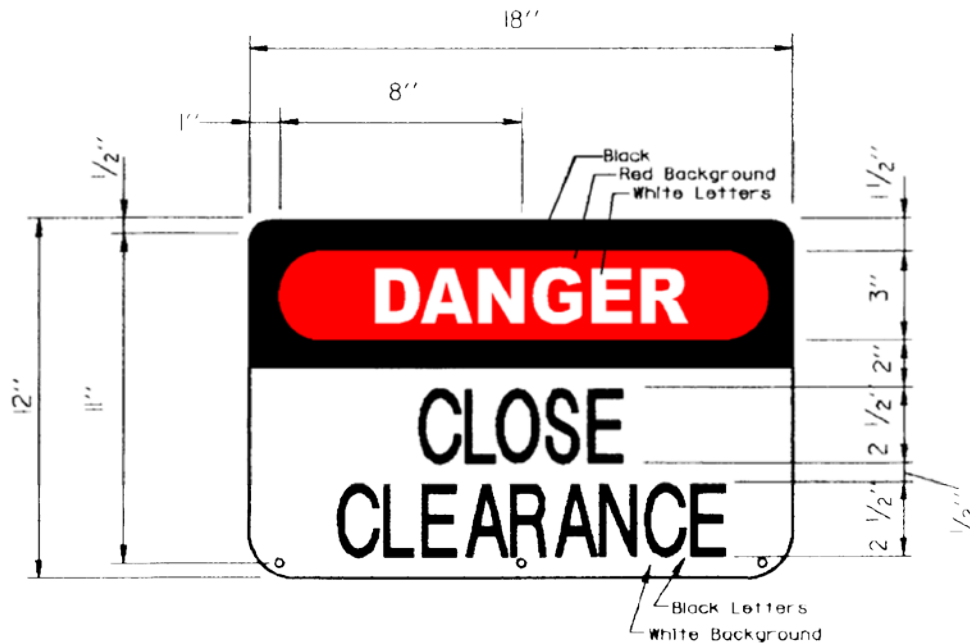

NOTES:

ALL LETTERS TO BE SERIES C IN ACCORDANCE WITH CURRENT US DOT-FHWA STANDARDS.

SIGNS: 0.080 ALUMINUM.
ALL HOLES SHALL BE $\frac{3}{8}$ " DIA. UNLESS NOTED.

FACING: ENGINEER GRADE REFLECTIVE SHEETING,
COLOR AS SHOWN.

LETTERS: AS NOTED.

POSTS: STANDARD SIGN POST.

LOCATION:

SIGNS SHALL BE PLACED AT A RIGHT ANGLE TO TRACK AND A MINIMUM OF 12'-0" FROM CENTERLINE OF TRACK THAT HAS SUB-STANDARD CLEARANCE.

WHERE TRACK HAS SUB-STANDARD CLEARANCE ON TRACK CONNECTED AT BOTH ENDS, SIGNS SHALL BE PLACED ON BOTH SIDES OF STRUCTURE, AT OR NEAR THE CLEARANCE POINT OF TURNOUT NEAREST THE STRUCTURE. IF THERE IS NO ROOM FOR POST, SIGN SHALL BE MOUNTED ON THE STRUCTURE. SIGNS ARE TO BE USED ON INDUSTRY LEAD TRACKS ONLY AS DIRECTED BY THE DIVISION SUPERINTENDANT.

**READING BLUE MOUNTAIN AND NORTHERN RAILROAD
ENGINEERING AND INDUSTRIAL DEVELOPMENT DEPARTMENTS**

PLAN NO: RBMN 10-0

CLEARANCES FOR TRACKS LOCATED ON INDUSTRY PROPERTY

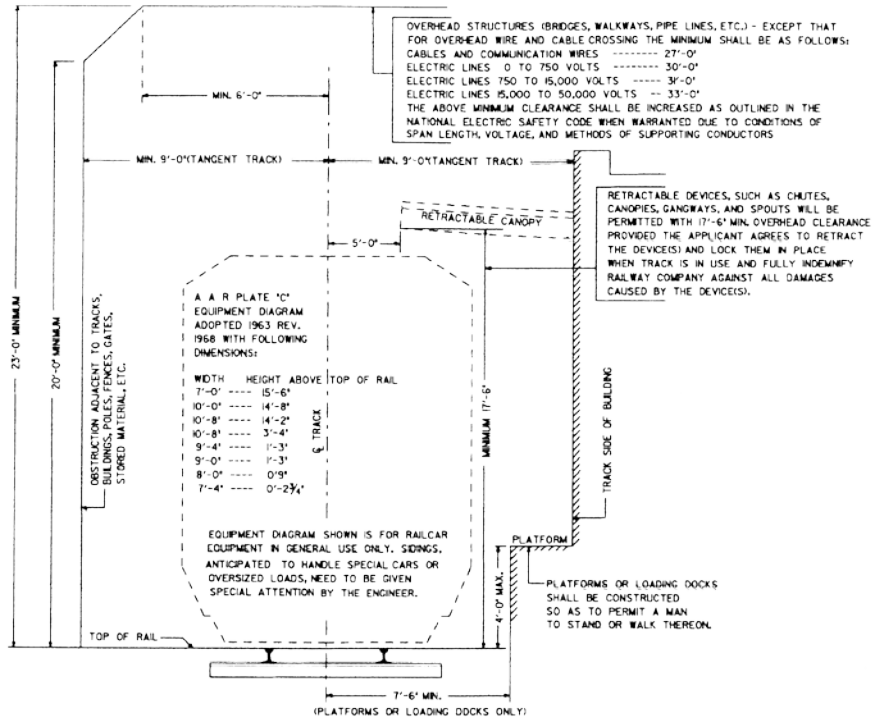

NOTE

- CLEARANCES APPLY BOTH TO STUB END TRACK AND TRACK CONNECTED AT BOTH ENDS.
- CLEARANCES APPLY BOTH TO OUTSIDE AND INSIDE OF BUILDING.
- DOORWAY FOR TRACK ENTERING BUILDING MUST HAVE 8'-0" SIDE CLEARANCE AND 22'-0" OVERHEAD CLEARANCE.
- SIGN MUST BE PLACED ON EACH SIDE OF DOORWAY TO WARN OF CLOSE SIDE CLEARANCE.
- INDUSTRY TRACK MUST NOT BE LESS THAN 15'-0" CENTER TO CENTER WITH MAIN AND RUNNING TRACK OF RAILWAY COMPANY. MINIMUM DISTANCE, CENTER TO CENTER, FOR ALL OTHER TRACKS TO BE 14'-0".
- ALL SIDE CLEARANCES MUST BE INCREASED 1 1/2 INCHES FOR EACH DEGREE OF CURVATURE.
- WHERE THE TRACK IS CURVED WITHIN 90 FEET OF AN ADJACENT OBSTRUCTION, THE SIDE CLEARANCES SHALL BE INCREASED AS PER TABLE IN UPPER RIGHT HAND CORNER.
- FOR ANY STRUCTURE CROSSING OR PROJECTING OVER TRACK, INDUSTRY MUST SUBMIT PLANS BEARING THE SEAL OF A REGISTERED PROFESSIONAL ENGINEER TO THE DIVISION SUPERINTENDENT FOR FORWARDING TO THE CHIEF ENGINEER BRIDGES AND STRUCTURES FOR APPROVAL.

ADDED SIDE CLEARANCES, REQUIRED FOR STRAIGHT TRACK AT END OF CURVE.

DISTANCE FROM ADJACENT OBSTRUCTION TO NEAR END OF CURVED TRACK	INCREASE IN SIDE CLEARANCE PER DEGREE OF CURVATURE.
0 - 22 FT.	1 1/2 INCHES
23 - 45 FT.	1 INCH
46 - 68 FT.	1/2 INCH
69 - 90 FT.	1/4 INCH

TABLE OF CURRENT STATE LEGAL CLEARANCE REQUIREMENTS

TRACK CENTERS	CLEARANCE									
	BETWEEN INDUSTRIAL TRACKS	INDUSTRIAL TRACKS BETWEEN MAIN & INDUSTRIAL TRACK	GENERAL	BUILDING DOORS	BUILDING DOORS OF TRACK	POLES			GENERAL	
						A	B	C		
VIRGINIA +										
ALABAMA +										
FLORIDA +	15'-6"	15'-6"	22'	17'	8'	5'-9"	CFH	8'	10'	8'
GEORGIA +										
ILLINOIS	15'-8"	15'	22'-4"	H	7'	6'-2"	CFH	8'	9'	8'
INDIANA	N	N	22'	17'	8'	*	N	8'	8'	8'
KENTUCKY	N	N	N	N	N	N	N	N	N	N
LOUISIANA +										
MISSISSIPPI +										
N. CAROLINA +										
OHIO	14'	8'	22'	20'	8'	*	N	8'	8'	8'
S. CAROLINA	N	N	N	N	N	N	N	N	N	N
TENNESSEE	15'	14'	22'	17'	8'	7'-6"	4'	8'	8'	8'
IOWA +										
MARYLAND	15'-8"	15'	22'	18'	8'	5'-7"	4'	8'-4"	8'-5"	8'-6"
MICHIGAN	14'	14'	22'-8"	22'-5"	8'-3"	N	N	8'-4"	8'-4"	8'-4"
MISSOURI	14'	14'	22'	22'	8'-3"	5'-9"	CFH	8'-6"	8'-6"	8'-6"
NEW YORK	15'-6"	15'	22'	18'	8'	8'-0"	4'	8'-0"	8'-0"	8'-0"
PENNSYLVANIA	15'-6"	15'	22'	18'	8'	8'-0"	4'	8'-0"	8'-0"	8'-0"
W. VIRGINIA	14'	15'	22'	22'	8'	6'-4"	4'	8'	8'	8'
DELAWARE**										
NEW JERSEY	N	N	N	N	N	N	N	N	N	N

ABOVE FROM A.R.E.A. CHART SHOWING LEGAL CLEARANCE REQUIREMENTS LAST REVISED AUGUST 10, 1996

NOTE:

- + NO CURRENT REGULATIONS
- CFH - CAR FLOOR HEIGHT
- H - HEIGHT OF CAR GOVERNS
- N - NO REGULATION GIVEN
- * - MUST APPLY TO STATE PUBLIC SERVICE COMMISSION FOR LESS THAN 8'-0" LATERAL CLEARANCE TO PLATFORMS.
- ** - A.R.E.A. STANDARDS APPLY

WHERE PUBLIC LAW OR REGULATION REQUIRES CLEARANCE MORE RESTRICTIVE THAN RAILWAY COMPANY STANDARD, SUCH LAWS AND REGULATIONS WILL GOVERN SEE ABOVE TABLE.

**READING BLUE MOUNTAIN AND NORTHERN RAILROAD
ENGINEERING AND INDUSTRIAL DEVELOPMENT DEPARTMENTS**

PLAN NO: RBMN 11-0

TRACK SPIKING PATTERN

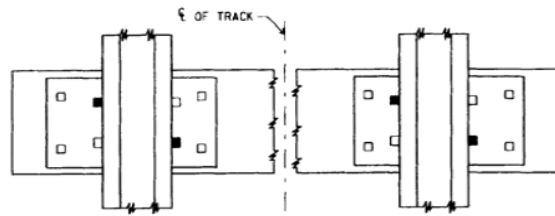

TANGENT

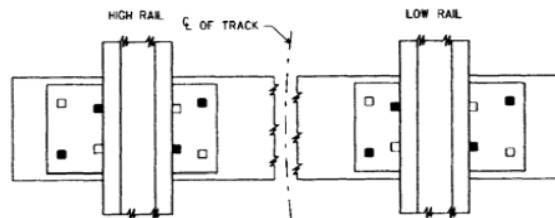

CURVE 2 DEGREE AND OVER

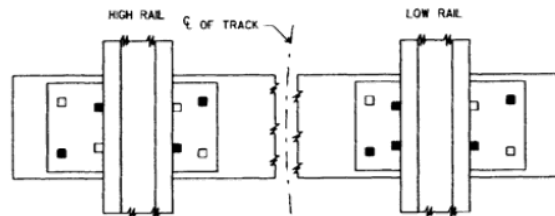

CURVE 5 DEGREE AND OVER

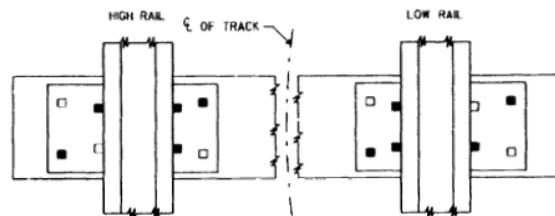

CURVE 6 DEGREE AND OVER

GENERAL NOTES

THE SPIKING PATTERN SHOWN APPLIES TO TRACKS CONSTRUCTED FOR MAIN LINE, BRANCHES AND PASSING SIDINGS; ALSO OTHER TRACKS WHERE THE SPEED IS IN EXCESS OF 25 MILES PER HOUR. THE SPIKING PATTERN ON CURVES TO BE UNIFORM THROUGHOUT TOTAL LENGTH OF CURVE, INCLUDING SPIRALS.

ALL TRACKS WITH TIMBER TIES ARE TO HAVE THE RAILS SPIKED WITH AT LEAST ONE RAIL HOLDING SPIKE ON THE GAGE SIDE AND ONE RAIL HOLDING SPIKE ON THE FIELD SIDE.

STANDARD TRACK SPIKES ARE $\frac{5}{8}$ " X 6" CUT SPIKE SHOWN ON STANDARD PLAN.

OTHER RAIL AND/OR PLATE HOLDING DEVICES MAY BE USED WHEN AUTHORIZED BY AVP MAINTENANCE.

WHEN ANY RE-SPIKING IS PERFORMED, OLD SPIKE HOLES MUST BE PLUGGED WITH WOOD.

SPIKES MAY BE DRIVEN WITH A STANDARD SPIKE MAUL OR WITH A MACHINE. SPIKES MUST BE STARTED AND DRIVEN VERTICALLY AND SQUARE TO THE TIE TO PROVIDE A FULL BEARING AT THE BASE OF RAIL.

RAIL HOLDING SPIKES AT EPOXY INSULATED JOINTS MUST BE REVERSED SO THAT THE TOE OF SPIKE WILL NOT CONTACT JOINT BAR. IF SPIKE IS UNDER THE BOLT, THE TIE MUST BE RE-SPACED.

ADDITIONAL SPIKES MAY BE USED WHERE NECESSARY TO MAINTAIN PROPER GAGE.

■ = SPIKE

READING BLUE MOUNTAIN AND NORTHERN RAILROAD
ENGINEERING AND INDUSTRIAL DEVELOPMENT DEPARTMENTS

PLAN NO: RBMN 12-0

EARTH MOUND DETAIL

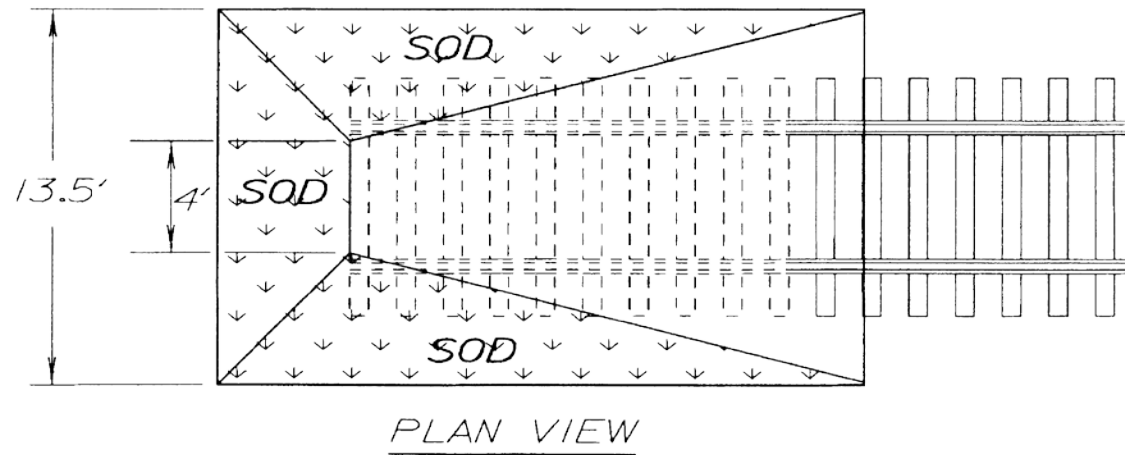
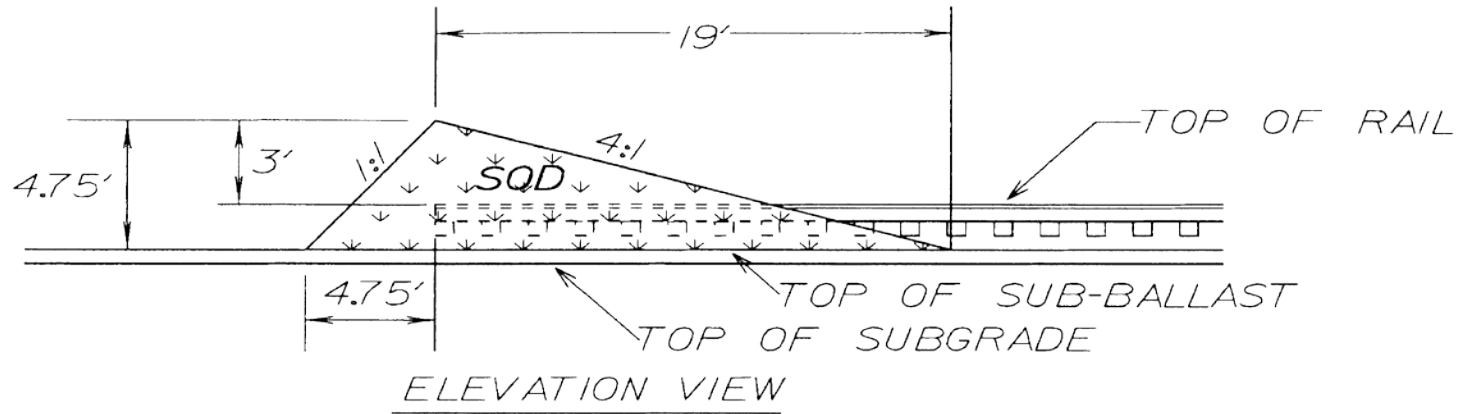

READING BLUE MOUNTAIN AND NORTHERN RAILROAD
ENGINEERING AND INDUSTRIAL DEVELOPMENT DEPARTMENTS

PLAN NO: RBMN 15-0

INSTALLATION INSTRUCTIONS FOR CORRUGATED METAL DRAINAGE STRUCTURES

PLACE MATERIAL (6" LAYERS ONLY) EVENLY ON EACH SIDE OF PIPE. STONES LARGER THAN 2" SHALL NOT BE USED

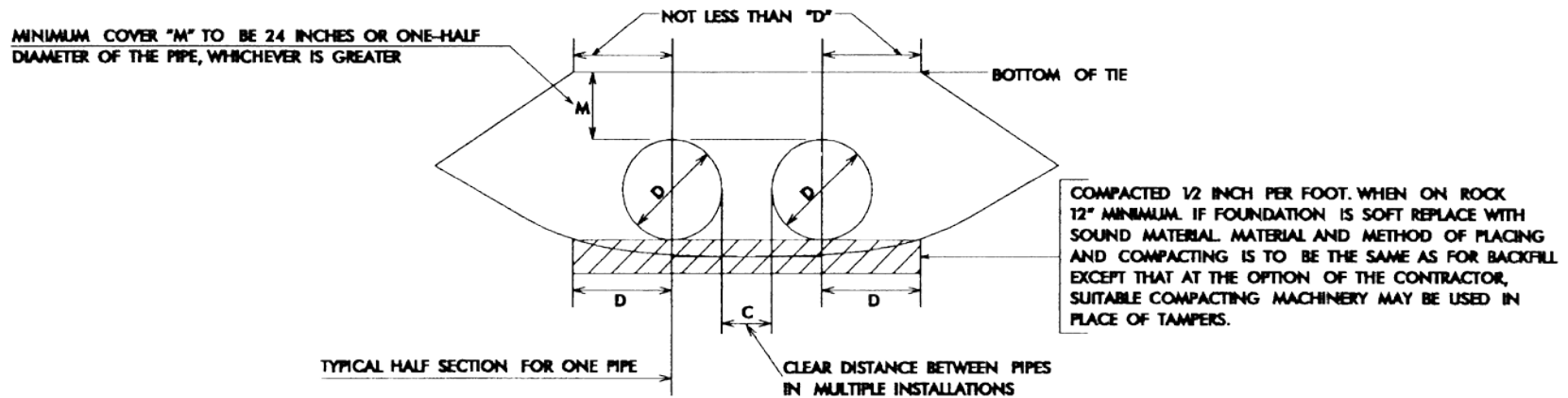

DETAILS FOR BEDDING AND BACKFILLING PIPE

PROTECTION: A REASONABLE AMOUNT OF CARE MUST BE TAKEN IN HANDLING CORRUGATED METAL DRAINAGE PRODUCTS TO PROTECT AGAINST CRACKING OR BREAKING THE PIPE OR DAMAGING THE GALVANIZED AND/OR OTHER COATING. HEAVY CONSTRUCTION EQUIPMENT MUST NOT BE RUN DIRECTLY OVER THE STRUCTURE UNTIL IT HAS BEEN BACKFILLED AND EMBANKMENT PLACED TO THE MAXIMUM HEIGHT ABOVE TOP OF PIPE AS SHOWN ON THE DRAWING.

STRUTTING: PIPES SHOWN TO BE SHOP STRUTTED WILL HAVE TWISTED WIRE OR ROD STRUTS. STRUTS SHALL BE HORIZONTAL WHEN PIPE IS PLACED.

CAMBER: UNDER HIGH FILLS, WHERE THE FOUNDATION IS SUBJECT TO SUBSIDENCE, THE GRADE LINE WILL BE CAMBERED TO PRODUCE A STRAIGHT GRADE AFTER SUBSIDENCE.

HAND TAMPED: WHEN APPROVED BY THE ENGINEER, A HAND TAMPER SHALL WEIGH NOT LESS THAN TWENTY (20) POUNDS AND HAVE A TAMPING FACE NOT LESS THAN 6"X6".

ASSEMBLY OF STRUCTURE: RIVETED CORRUGATED METAL PIPES MUST BE PLACED WITH THE INSIDE CIRCUMFERENTIAL LAPS POINTING DOWNSTREAM. THE LONGITUDINAL LAPS SHOULD BE AT THE SIDES OR QUARTERPOINTS BUT NOT IN THE BOTTOM. STRUCTURAL PLATE PIPES WILL BE ASSEMBLED FROM DETAILED ERECTION INSTRUCTIONS WHICH ACCOMPANY EACH PIPE WHEN SHIPPED.

BEDDING AND BACKFILLING: BEDDING AND BACKFILL MATERIAL SHALL BE DENSE GRADED CRUSHED STONE MAXIMUM SIZE 2 INCHES TO DUST. BACKFILL IS TO BE PLACED IN LAYERS NOT LESS THAN 4" OR MORE THAN 6" AND COMPACTED WITH MECHANICAL TAMPERS TO 100% STANDARD PROCTOR. HEAVY EARTH COMPACTING EQUIPMENT SHALL NOT BE USED OVER THE PIPE UNTIL BACKFILL HAS BEEN COMPLETED AS SHOWN AND SPECIFIED ON THE PLAN. CARE MUST BE TAKEN NOT TO STRIKE THE PIPE WITH THE TAMPER.

MULTIPLE LINES OF PIPE

PIPE DIAMETERS MINIMUM

UP TO 72"
72" TO 180"

CLEARANCE "C"

ONE HALF DIAMETER OF PIPE
36"

**READING BLUE MOUNTAIN AND NORTHERN RAILROAD
ENGINEERING AND INDUSTRIAL DEVELOPMENT DEPARTMENTS**

PLAN NO: RBMN 16-0

CORRUGATED METAL CULVERT GAGE SELECTION AND INSTALLATION

CORRUGATED METAL PIPE		GAGE TABLE FOR 2 2/3' X 1/2' CORRUGATIONS									
AREA (SQ. FT.)	DIA. (IN.)	HEIGHT OF COVER (FEET)									
		1-10	11-20	21-30	31-40	41-50	51-60	61-70	71-80	81-90	91-100
1.8	18										
2.4	21								10	10	
3.1	24							10	10	10	
4.9	30					10	10	10	8*	8*	8*
7.1	36				10	8	8	8*	8*	8*	8*
9.6	42			10	8	8					
12.6	48	USE ELONGATED CORRUGATED METAL PIPE FOR THESE TABULAR VALUES									
13.9	54										
19.6	60										
23.8	66										
28.3	72										

ELOGATED CORRUGATED METAL PIPE		GAGE TABLE FOR 2 2/3' X 1/2' CORRUGATIONS											
DIA. (IN.)		HEIGHT OF COVER (FEET)											
		1-10	11-20	21-30	31-40	41-50	51-60	61-70	71-80	81-90	91-100		
18		USE ROUND CORRUGATED METAL PIPE FOR THESE TABULAR VALUES											
21													
24													
30													
36													
42									8	8*	8*	8*	8*
48	10	10	8	8	8	8	8*	8*	8*	8*			
54	8	8	8	8	8*	8*	8*	8*					
60	8	8	8	8	8*								
66	8	8	8*										
72	8	8*											

NOTES

* Trench One (1) Diameter

1. **MINIMUM DIAMETER:** TO BE 36" UNLESS APPROVED BY BRIDGE OFFICE.
2. **MATERIAL:** TO BE GALVANIZED STEEL ASTM A 444-89, WITH 2 2/3" X 1/2" ANNULAR CORRUGATION.
3. **COATING:** PIPE AND BANDS TO BE FULLY ASPHALT COATED.
4. **CONNECTING BANDS:** MAY BE (ONE) GAGE LIGHTER THAN CULVERT MATERIAL. ALL BANDS UNDER COMPANY OWNED TRACKS ARE TO BE ONE PIECE, 2 FEET WIDE. CULVERTS 48" DIAMETER AND LARGER TO USE 2 FOOT BAND WITH 4 - 1/2" DIAMETER RODS AND SILO LUGS.
5. **INSTALLATION:** TO BE IN ACCORDANCE WITH THE STANDARD PLAN. WHERE CULVERTS ARE INSTALLED IN OPEN CUT TO REPLACE FAILED CULVERTS, BEDDING AND BACKFILL TO BE CRUSHER RUN STONE.
6. **ELONGATED PIPE:** SHALL NOT HAVE LESS THAN 5% VERTICAL ELONGATION. ELONGATED PIPE 48" IN DIAMETER AND LARGER SHALL BE SHOP WIRE STRUTTED.
7. **EXCEPTIONS:** THE GAGE TABLES ARE TO PROVIDE ADEQUATE STRENGTH. EXCEPTIONS MUST BE CLEARED BY BRIDGE OFFICE. WHERE KNOWN CONDITIONS WILL AFFECT THE SERVICE LIFE OF THE CULVERT, ADDITIONAL GAGE REQUIREMENTS WILL BE FURNISHED BY THE BRIDGE OFFICE.
8. **MINIMUM COVER:** SHALL BE 24" OR 1/2 THE PIPE DIAMETER, WHICHEVER IS GREATER, AS MEASURED BETWEEN THE BOTTOM OF THE TIE AND THE TOP OF THE PIPE. EXCEPTIONS TO THIS CRITERIA WILL BE CONSIDERED ON AN INDIVIDUAL BASIS.

*READING BLUE MOUNTAIN AND NORTHERN RAILROAD
ENGINEERING AND INDUSTRIAL DEVELOPMENT DEPARTMENTS*

PLAN NO: RBMN 17-0

CRITERIA FOR TEMPORARY SHEETING AND BULKHEADS TO PROTECT RAILWAY TRACK DURING ADJACENT STRUCTURE CONSTRUCTION

1. THE LIVE LOAD SURCHARGE FROM TRACK ADJACENT TO SHEETING AND BULKHEAD SHALL BE TAKEN INTO ACCOUNT IN THE SHEETING AND BULKHEAD DESIGN.
2. ALLOWABLE STRESSES CONTAINED IN THE "AMERICAN RAILWAY ENGINEERING ASSOCIATION SPECIFICATIONS" (CHAPTERS 7, 8 AND 15) SHALL BE USED.
3. A CONSTRUCTION PROCEDURE FOR TEMPORARY SHEETING AND BULKHEAD CONSTRUCTION SHALL BE INCLUDED ON THE DRAWINGS.
4. SAFETY RAILINGS SHALL BE INSTALLED WHEN TEMPORARY SHEETING OR BULKHEADS ARE WITHIN 15 FT. OF TRACK.
5. A SAFETY FACTOR OF 2 SHALL BE USED IN THE TEMPORARY SHEETING OR BULKHEAD.

DRAWINGS AND CALCULATIONS NEEDED FOR APPROVAL

1. 3 COPIES OF DETAILED DRAWINGS SHOWING THE FOLLOWING:
 - A. TIMBER, STEEL, BOLT AND WELD SIZES AND DETAILS.
 - B. DIMENSIONS SHOWING DISTANCES FROM CENTERLINE TRACK TO TEMPORARY SHEETING AND BULKHEADS AND BETWEEN SUPPORTING ELEMENTS.
 - C. SECTION SHOWING TEMPORARY SHEETING OR BULKHEAD HEIGHTS AND TRACK ELEVATION.
2. CALCULATIONS COVERING TEMPORARY SHEETING AND BULKHEAD DESIGN.

LIVE LOAD

(A) THE RECOMMENDED LIVE LOAD FOR EACH TRACK IS THE COOPER E80 LOAD, SHOWN IN THE FIGURE BELOW.

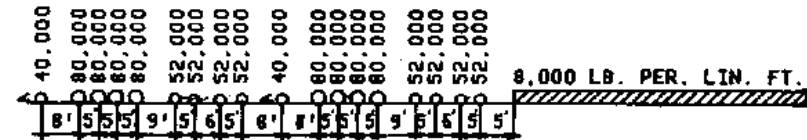

FIGURE 2

MINIMUM ROADBED SECTION FOR CONSTRUCTION ADJACENT TO TRACKS

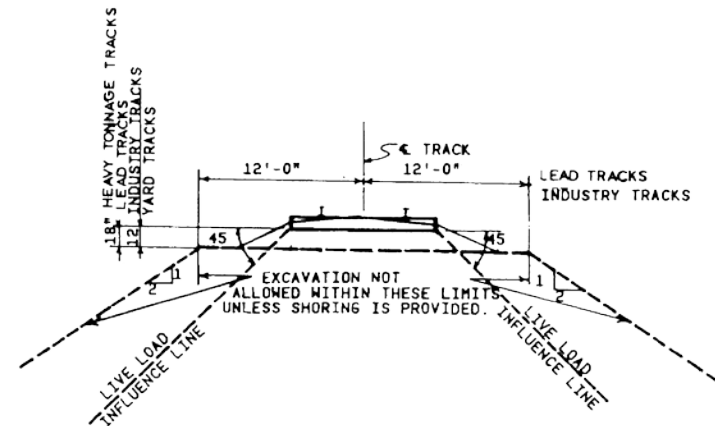

FIGURE 8

NOTE: CONTRACTOR TO PROVIDE HANDRAIL PROTECTION FOR EXCAVATION ADJACENT TO TRACK.

**READING BLUE MOUNTAIN AND NORTHERN RAILROAD
ENGINEERING AND INDUSTRIAL DEVELOPMENT DEPARTMENTS**

PLAN NO: RBMN 18-0

OIL SIDING PROTECTION FROM STRAY ELECTRIC CURRENTS

NOTE:

Plain joints in protected section to be banded with Plug Type band wires. The first rail on either side of the insulated joints in the oil siding must be not less than 85 lb section.

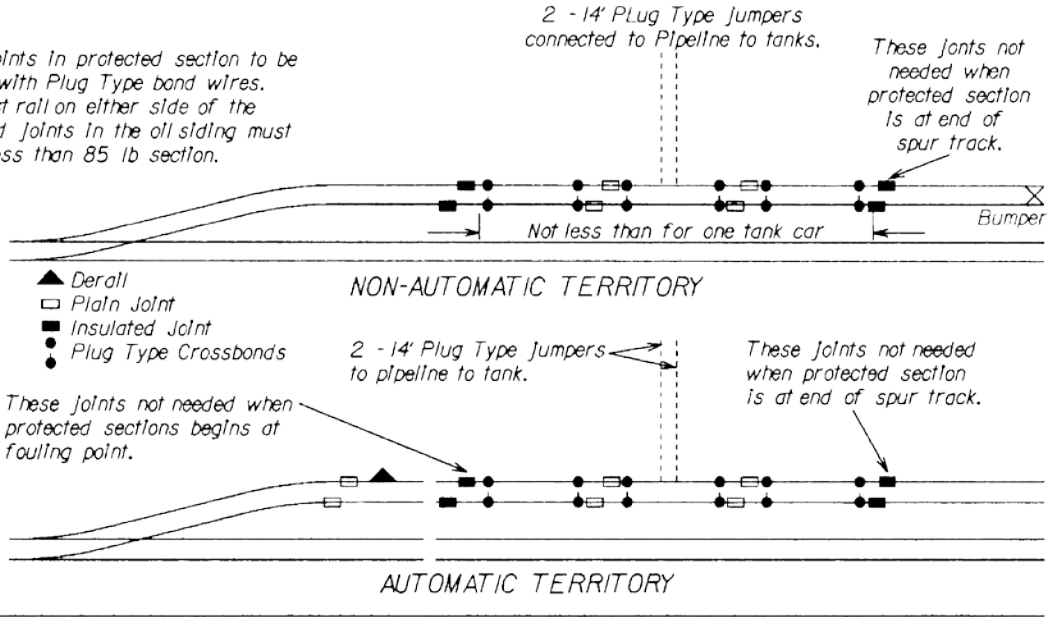

NOTE:

Before unloading tank car, all other cars should be separated from it and placed outside the limits of protected section. Crossbands to be used as shown. When pipe connected derail is located in protected section, insulate pipeline opposite insulated joint in outside rail.

Shawmut Ground Clamps
Nos. 3660 to 3668
(F.D. Lawrence Elet. Co. Cat)

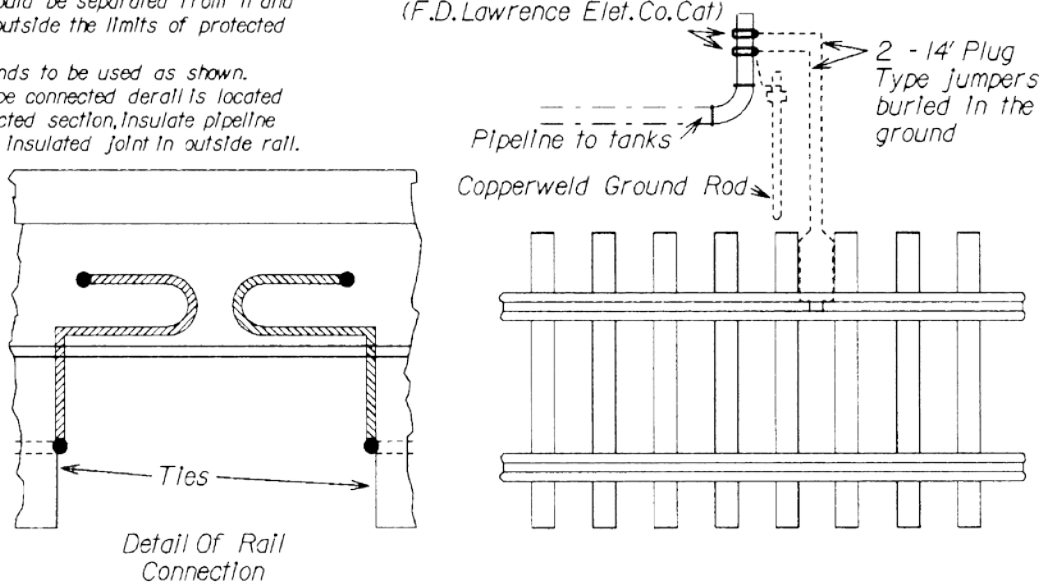

"Holes for web bond connections must be at least 8 inches horizontally from any thermit rail weld."

**READING BLUE MOUNTAIN & NORTHERN RAILROAD
ENGINEERING AND INDUSTRIAL DEVELOPMENT DEPARTMENTS**

PLAN NO: RBMN 19-0

IT'S A RULE

SWITCHES

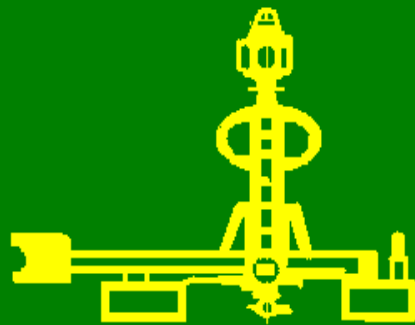

**LINED
AND
LOCKED?**

MAIN CLEAR ?

**READING BLUE MOUNTAIN & NORTHERN RAILROAD
ENGINEERING AND INDUSTRIAL DEVELOPMENT DEPARTMENTS**

SIGN DIAGRAM NO: RBMN 20-0

TWO BLADED POINTED/SQUARE TARGET

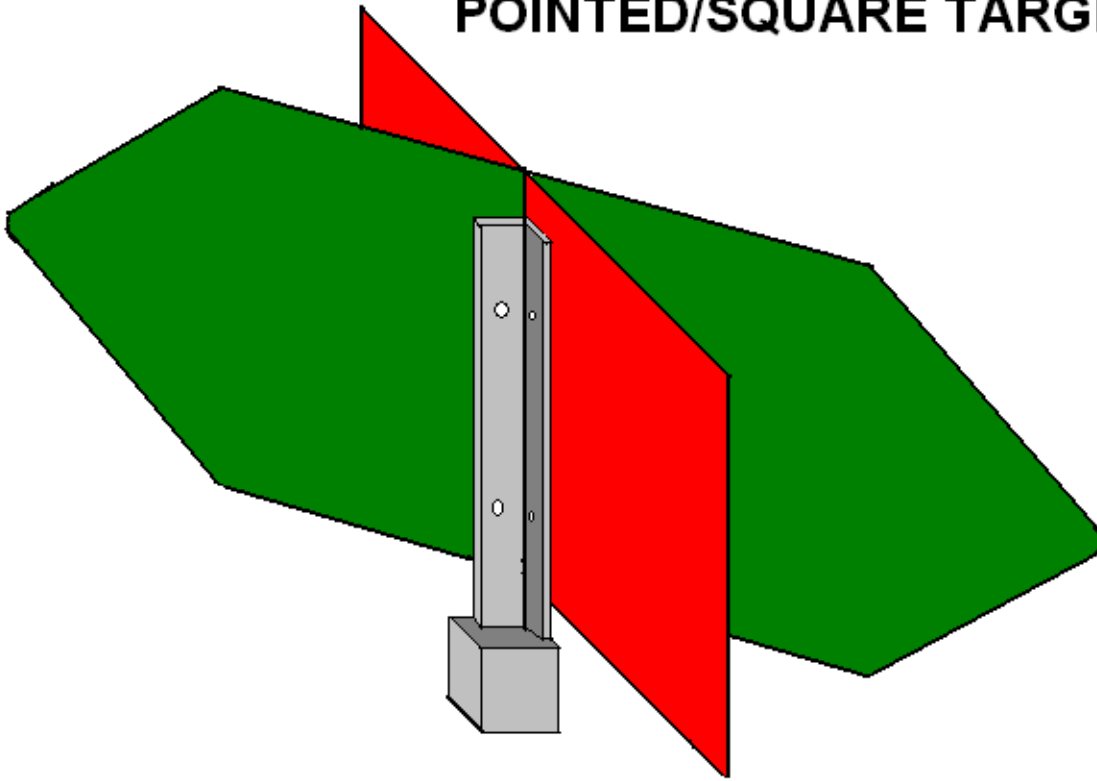

*READING BLUE MOUNTAIN & NORTHERN RAILROAD
ENGINEERING AND INDUSTRIAL DEVELOPMENT DEPARTMENTS*

SIGN DIAGRAM NO: RBMN 21-0



bottom line reads:
PROPERTY OF READING AND NORTHERN RR CO. PO BOX 218 PORT CLINTON PA 19549 610-562-2100 www.RBMNRR.com
Note extra spacing, and use of att. number 1 in address and phone no.

**READING BLUE MOUNTAIN & NORTHERN RAILROAD
ENGINEERING AND INDUSTRIAL DEVELOPMENT DEPARTMENTS**

SIGN DIAGRAM NO: RBMN 22-0